

Volume 7 Issue 1

ISSN: 2456-7035



ISF Institution of Research and Education (IIRE)

**IIRE JOURNAL
OF
MARITIME RESEARCH AND DEVELOPMENT
(IJMRD)**

April 2023





ISF Institute of Research and Education (IIRE)

**IIRE JOURNAL
OF
MARITIME RESEARCH AND DEVELOPMENT
(IJMRD)**

April 2023

Knowledge-Humility-Excellence

The IIRE Journal of Maritime Research and Development (IJMRD) provides a forum for critical reviews and research findings that underpin scientific foundations of all decisions. Selection of articles for publication in the IJMRD is completely merit based and articles are published only if favorable review and approval is received from a referee.

The concepts, views, expressions, and examples in the published articles of IJMRD are those of the authors and not necessarily of the journal. The responsibility for the content of the articles remains exclusively with the author(s) concerned.

The Publishing team of IIRE does not necessarily subscribe to views expressed in the articles published under its banner. IIRE as the publisher disclaims any liability to any party for any loss, damage, or disruption caused by errors or omissions, whether such errors or omissions result from negligence, accident, or any other cause.

The copyright of the articles published under IIRE in its Journal of Maritime Research and Development (IJMRD) rests with the author(s) concerned, who may be contacted for any clarifications and/or reproduction rights.

ISSN: 2456-7035

Published by:

ISF INSTITUTE OF RESEARCH AND EDUCATION (IIRE)

410, Gemstar Commercial Complex, Ramchandra Lane Ext, Kachpada,
Off Link Road, Malad West, Mumbai 400 064, India.

Website: www.iire.in, www.inner-search.org, www.isfgroup.in

Place of Publication: - Mumbai

IIRE Journal of Maritime Research and Development

Maritime sector has always been influencing the global economy. Shipping facilitates the bulk transportation of raw material, oil and gas products, food, and manufactured goods across international borders. Shipping is truly global in nature, and it can easily be said that without shipping, the intercontinental trade of commodities would come to a standstill.

Recognizing the importance of research in various aspects of maritime and logistic sector, IIRE through its Journal of Maritime Research and Development (IJMRD) encourages research work and provides a platform for publication of articles, manuscripts, technical notes, papers, *etc.* on a wide range of relevant topics listed below:

- Development in Shipping
- Ship Operations and Management
- Risk Assessment and Risk Management in Maritime Sector
- Maritime Safety and Environmental Protection
- Technological Developments
- Maritime Education
- Human Resource in Maritime Sector
- Trade Liberalization and Shipping
- Freight Rates Fluctuations and Forecasting
- Commodity Markets and Shipping
- Shipping Investment and Finance
- Maritime Logistics
- Multimodal Transport
- Inland Waterways Transport
- Maritime Statistics
- Port Management, Port Pricing and Privatization
- Economic and Environmental Impact of Shipping and Ports
- Other Current Topics of Interest in Shipping

Editorial Board

Chief Editor



Dr. Captain Suresh Bhardwaj, Master Mariner, India
Resident Director and Principal, MASSA Maritime Academy
Email ID: - capt.s.bhardwaj@gmail.com

Managing Editor



Dr. Poonam Kapoor, India
President: Inner Search Foundation, Director: ISF Institute of Research and Education, Director: ISF Maritime Services Pvt. Ltd.
Email ID: - poonamkapoor@isfgroup.in

Members



Prof. (Dr.) Koombel Antony Simon
Director, Albert Maritime Institute. Cochin.
Email ID: - kasimon2000@yahoo.com



Dr. Bani Ghosh, International Maritime Business, USA
Professor, Department Chair, International Maritime Business
Email ID: - bghosh@maritime.edu



Dr. Margareta Lutzhoft, 1st degree connection
Professor in MarSafe group at Western Norway, University of Applied Sciences, Haugesund, Rogaland, Norway.
Email ID: - Margareta.Lutzhoft@utas.edu.au



Prof. V. Anantha Subramanian, India
Department of Ocean Engineering, IIT Madras
Email ID: - subru@iitm.ac.in



Dr. Thomas Pawlik, International Maritime Business
Dean of Studies, Bremer Rhederverein, Chair of Maritime Management, Germany
Email: Thomas.Pawlik@hs-bremen.de



Dr. M. Abdul Rahim CEng CMarEng FIMarEST FRINA
Regional Manager, South Asia and Middle East ClassNK Dubai
Email: rahim@classnk.or.jp



Dr. Amit Mokashi, United States
New Jersey City University
Email ID: - AMokashi@njcu.edu, amit_j_m@yahoo.co.in



Dr. Rajoo Balaji, Marine Engineer,
Director Chennai Campus IMU, India
Email ID: - director.chennai@imu.ac.in

Editorial

The Econometric Institute Report of Erasmus University Rotterdam, “Analysis of the Maritime Inspection Regimes – Are ships over-inspected?” points out the lack of trust in the maritime industry between all the industry organizations and regulators having created an inspection industry which is heavily controlled by oil majors in order to limit their liability. Interestingly, the results reveal that certain ships are inspected frequently, and that over-inspection does not necessarily decrease the probability of having a casualty but can rather increase it.

Inspections result in mere corrections which are more focused on the ship situations. It does not address root-cause. This ideally suits the Insurance regime too because shipboard errors are covered. So how will improvements come.

The moot question arises, why the safety record of shipping industry is so abysmally low?

The highly fragmented structure of the globalised shipping industry necessitates a regulatory-driven environment for its basic administration. In the safety-critical nature of the industry, regulatory updates then become the basis for lessons learned from the analysis of incidents and accident investigations. While safety requires attention to how workers negotiate risks and uncertainties in everyday practice, in the contemporary shipping industry there is no focus on ‘performance influencing factors’ by the organizations thereby putting the experienced, trained, certified competent seafarer to utmost stress and fatigue. As a consequence, interpretations of accidents by ‘experts’ as matters of human error by the crew acquire the status of fact, further compounding the disempowered position of workers and a general downward spiral in safety practices.

Coming to the articles in this issue....

This issue contains an ambitious research work on the Maritime Strategy and Policy for the African Union by a Maritime Law faculty at the Massachusetts Maritime Academy, USA.

Another paper dwells on the Mental and Emotional preparation for Seafaring career that is denuding and has its unique set of challenges.

The Faculty and students of Indian Maritime University are engaged in developing an Electric Vehicle for their campus in Chennai and this research effort is enunciated in another paper carried in this issue.

Lead Naval Architects and Structural Engineers detail the structural engineering challenges in

converting a Mobile Offshore Drilling Unit to Mobile Offshore Production Unit in another paper carried in the issue.

No discussion on Maritime can be complete without talking about Safety in this Safety critical industry. The last paper looks at the various data sources for maritime accident investigation and calls for a more harmonised and standardised approach to data and reporting for an effective analysis and corrective actions.

Happy reading!

Dr. (Capt.) S. Bhardwaj *fic, fni, fcmmi*
PhD (Denmark and UK),
Resident Director and Principal,
MASSA Maritime Academy, Chennai.

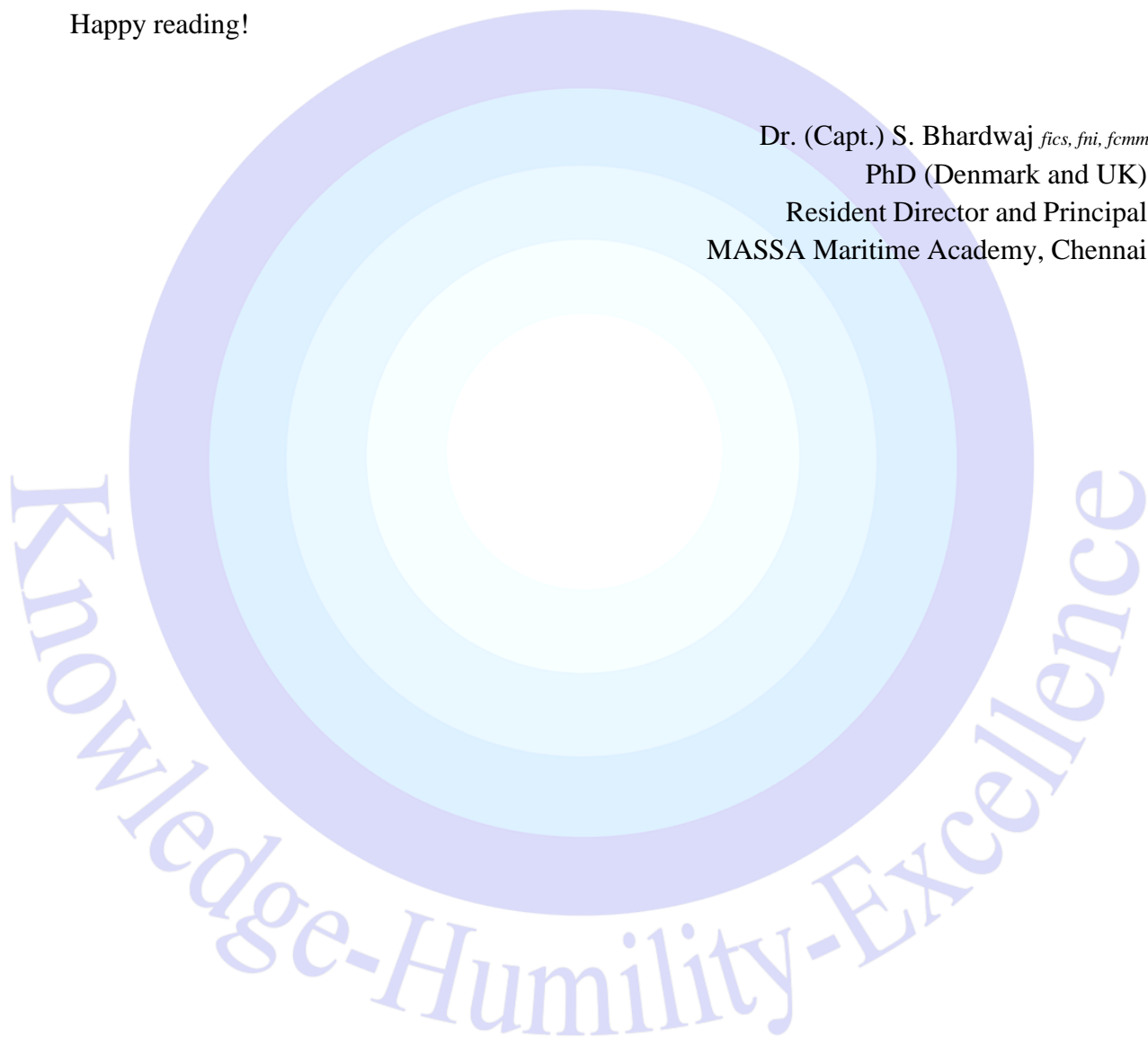

**IIRE Journal of Maritime Research and Development
(IJMRD)**

Volume 7 Issue 1, April 2023

MARITIME POLICY AND STRATEGY FOR AFRICAN COASTS1

DR FIKILE PORTIA NDLOVU

**TOWARDS A HARMONIZED APPROACH: UNDERSTANDING DATA
SOURCES FOR MARINE INCIDENT AND ACCIDENT ANALYSIS... 26**

DR POONAM KAPOOR
MS YOGYATA KAPOOR
MR ABDULLAH SIDDIQUE

**STRUCTURAL ENGINEERING CHALLENGES IN A MODU TO MOPU
CONVERSION PROJECT 49**

MR THOMAS STEPHEN
MS NEETHU NARAYANAN
MR TOMIN MATHEW

MENTAL AND EMOTIONAL PREPARATION FOR SEAFARERS55

DR POONAM KAPOOR

BUILDING AN ELECTRIC VEHICLE FOR A MARITIME CAMPUS..70

DR. S. THANGALAKSHMI
MR BESSETTY AYUS
MR SAAD KHAN
MR RAJ JITENDRA SINGH
MR AKSHAY A KUMAR

MARITIME POLICY AND STRATEGY FOR AFRICAN COASTS

Dr Fikile Portia Ndlovu¹

Abstract

In modern African coastal and all other waterborne navigation, there have definitely been success stories and also harrowing moments which have raised concerns about the safety of coastal personnel, cargo and the ship. However, it is important to highlight that there is a continent wide, purposeful maritime strategy and vision for industry participants engaged in trade, commerce, supply chain and logistics. This paper seeks to highlight Africa's ambitious and achievable Maritime Strategy, the policy around the vision of the strategy and how its goals will be achieved, and the significant bodies committed to making this possible for the African Continent. The maritime industry is global in nature, and it is every important to perceive the African maritime policy voice more and more going forward and to consider data on the relationship between the African continent, the future success vision the continent has for itself and the international treaties to make the industry successful for its participants around the globe. What is evident in this paper is that just like the silver mines of Laurion saved ancient Greece by providing great funding for the Greek navy, military power on the waters is still going to be the force behind making any coasts safe and successful for maritime trade and other ocean and water related positive activities, therefore collaboration in the exercising of such power by the developed world with African States is still going to be the secret sauce of global equitable, peaceful trade African navigation. This conversation is even more important as scientists inform us that the Nubian tectonic plates are moving in Somalia to reveal another ocean in Africa, even though these phenomena will take many more millennia.

Keywords: Maritime, Insurance, Risk management, Controlled Tonnage, Arbitration, IMAA.

1. INTRODUCTION

Africa is one as a continent and this is demonstrated, not only geographically but also through various African regional developmental community bodies such as the African Union (AU). The AU being the biggest regional body represents that oneness of the African continent while having due regard to the sovereignty of each of the member nations Africa represents. The goals of the

¹ Distinguished Professor of International Maritime Business, Lawyer, Author, and Speaker from Durban, South Africa. She specializes in maritime law and international trade, with a focus on environmental law, maritime security, and mining of sea areas.

Email: pndlovu@maritime.edu

AU of supporting peaceful trade and economic development are not too different from the economic goals of the Western post-World War II Bretton Woods Conference, which was created to among other things, to enable creating a dynamic global economy in which ‘peoples of every nation will be able to realize their potentialities in peace and joy increasing the fruits of material progress of an earth infinitely blessed with natural riches.’ The trade and economic prosperity of the African continent and the world is directly linked to shipping and the rules that support safe navigation of vessels. These are the aspects that will be deliberated on in this paper, particularly with the very serious commitment by the AU to Africa’s Integrated Maritime Strategy (The 2050 AIM Strategy).

Since Africa, for the purposes of this paper, is represented by 55 member States of the AU, although some States may be facing suspension because of ongoing conflicts, it is important to note the following points. It would be unmanageable to account for all single African country’s navigation rules and regulations in an in-depth manner without writing a tome. This paper is not intended to be a thorough tome on all African navigation rules. Therefore, a more contextually practical approach of discussing the African perspective on navigation will necessitate looking at a systematic selection of some African nations and their commitments to international rules of navigation. It is submitted that this approach will capture the African perspective in a more appropriately succinct manner for a work of this nature. The system employed in the selection of nations (for the sake of sampling) to be discussed in this paper will involve a consideration of regulations around topics such as warship passage, nuclear waste carrying ships passage, and the controversies around navigating, for example, areas on African coasts such as the now historical Libyan ‘Line of Death’ in the Gulf of Sidra.

Parts of this paper are also intended to inspire further discussion and more reading about African navigation in similar papers, books, and other material from research all over the continent and world so that African navigational interests are discussed specifically with the unique attributes of the continent being noted. See, for example, Figure 1 below, tonnage and vessel registration statistics by Clarksons Research for the United Nations Conference on Trade and Development (UNCTAD), placing Africa in Developing Economies grouping which does not have much tonnage when compared to nations such as Germany, Japan, and Greece.

The second point to note that while we will be considering navigation from an African continental perspective, ship registration and vessel ownership is influenced by factors that may create uncertainty as to the true numbers of African vessels since vessels can easily change nationalities

through the practice of registering vessels under flags of convenience (FOC) States and other dynamic sale and purchase agreements of ships. Further, navigation around Africa is greater than just merchant shipping or vessel ownership, there is also aspects of port services (consider for example, the importance of the Port of Kamsar in Guinea which is such an important bauxite bulk port that a special vessel, the Kamsarmax ship, was created with specific reference to that port), naval activity, fishing, cruise shipping and private pleasure cruising with aspects of national safety and other environmental concerns which form part of the navigation exchange of ideas.

Figure 1 Table: Sources: UNCTADstat (UNCTAD, 2020a); Clarksons Research.

Table 1 | Merchant fleet registration by group of economies

Group of economies	2015				2020			
	Tonnage		Vessels		Tonnage		Vessels	
	(Millions of dwt)	Share in world (Percentage)	(Thousands)	Share in world (Percentage)	(Millions of dwt)	Share in world (Percentage)	(Thousands)	Share in world (Percentage)
World	1 753	100.0	90	100.0	2 069	100.0	98	100.0
Developing economies	1 333	76.1	59	65.6	1 607	77.7	67	68.4
Developing economies: Africa	230	13.1	6	6.9	294	14.2	7	7.6
Developing economies: America	450	25.7	16	17.8	446	21.5	16	16.3
Developing economies: Asia and Oceania	654	37.3	37	40.9	867	41.9	44	44.4
Transition economies	11	0.6	4	4.2	12	0.6	4	4.1
Developed economies	405	23.1	25	28.1	447	21.6	26	26.1
Selected groups								
Developing economies excluding China	1 255	71.6	55	61.0	1 506	72.8	61	62.1
Developing economies excluding LDCs	1 104	63.0	53	58.5	1 316	63.6	60	61.2
LDCs	229	13.1	6	7.1	291	14.0	7	7.2
LLDCs	5	0.3	1	1.2	3	0.1	1	1.1
SIDS (UNCTAD)	279	15.9	8	8.8	361	17.5	9	8.9
HIPCs (IMF)	220	12.6	5	5.8	284	13.7	6	6.3
BRICS	106	6.1	9	10.0	134	6.5	12	12.0
G20	527	30.0	45	49.2	612	29.6	50	50.5

Note: Commercial ships of 100 GT and above. Figures refer to the beginning of the year.

The second point to note that while we will be considering navigation from an African continental perspective, ship registration and vessel ownership is influenced by factors that may create uncertainty as to the true numbers of African vessels since vessels can easily change nationalities through the practice of registering vessels under flags of convenience (FOC) States and other dynamic sale and purchase agreements of ships. Further, navigation around Africa is greater than just merchant shipping or vessel ownership, there is also aspects of port services (consider for example, the importance of the Port of Kamsar in Guinea which is such an important bauxite bulk port that a special vessel, the Kamsarmax ship, was created with specific reference to that port), naval activity, fishing, cruise shipping and private pleasure cruising with aspects of national safety and other environmental concerns which form part of the navigation exchange of ideas.

FOC States allow the owner of the ship and the ship not to be registered for shipping business in the same country therefore the question of, 'How many African nations own ships?' is a question we can assess from these examples of FOC States (Antigua and Barbuda, Bahamas, Barbados, Belize, Bermuda (UK), Bolivia, Cambodia, Cayman Islands, Comoros, Cyprus, Equatorial Guinea, Faroe Islands (FAS), French International Ship Register (FIS), German International Ship Register (GIS), Georgia, Jamaica, Lebanon, Liberia, Malta, Madeira, Marshall Islands (USA), Mauritius, Moldova, Mongolia, Myanmar, Netherlands Antilles, North Korea, Panama, Sao Tome and Príncipe, St Vincent, Sri Lanka, Tonga, Vanuatu) but these will not always show the actual African ship ownership strictly speaking and this must be taken into account when conversing about African ship related matters. This also means that, indeed true to the nature of the rules of the shipping world, and the 1982 United Nations Convention on the Law of the Sea (LOSC) African economic activity, trade, navigation and other maritime activity can be given priority in many ways to support its study and development, but it cannot strictly be studied in isolation from the rest of the world.

Further, in the age of wildly viral, 'fake news' and other wild conspiracy theories, we all have to become even more discerning about the literature we consume, this is why by way of introduction, this paper submits that it is intended to create a positive discourse that encourages understanding between Africa and the rest of the world with respect for just rules of law.

There are many theories on the prosperity building and proposal for mutually beneficial peace proposed under the ideals of Pan-Africanism such as those discussed in the book, *Peacebuilding in the African Union: Law, Philosophy and Practice* by author Jeng Abou where the author discusses the history and theories on the development of African unity ideals, a necessary reading among many others to help us understand the international political and trade environment Africa has grown and continues to grow under. This paper therefore concentrates more on the legal aspects of supporting African trades and navigation in the modern world on the basis that rules of law must maintain justice.

Justice must be strived for even though it is not possible to find a utopia or a perfect government or intergovernmental structure. This is because human nature does have a dark side and the strong can bully the weak. It is also possible for big organizations to be looked at suspiciously as crimes, unfairness, competing interests or genuine misunderstandings find their way into many aspects of life all over the world. Therefore, equitable rules of justice are reinforced and advocated in this

paper on aspects of navigation focusing on practices that relate specifically to advancing participation, representation and supporting economic stability from the African perspective.

2. VESSEL NAVIGATION AND AFRICAN NATIONS

When discussing navigation in Africa, we must specifically mention each of the nations that are directly affected by their commitment to the African Union big picture and maritime strategic road map as mentioned in the 2050 AIM Strategy. However, it must be noted that the current list can be affected by changes such as AU sanctions against a listed country by the organization because of political activities such as military coups or nonpayment of AU dues. Further, navigation is directly linked to aspects of geography. By mentioning involved nations specifically as they currently appear the paper is emphasizing and impressing upon their commitment to the AU maritime policy while keeping in mind each nation's attributes in terms of access, control and management of their waterways, whether inland or coastal. Further, since we are discussing African matters of unity and maritime cooperation, we must have a general introduction to nations involved specifically so that we have a wider understanding of who the stakeholders are in African navigation are and which nations have committed to a better maritime future for Africa. Not only that, but it is also important to note how these listed nations through the AU are expected to cooperate in terms of military strategy and intelligence gathering to assist in maritime regional threats. Of course, it would be impossible to discuss every single nation in an in-depth manner in this paper, however starting with this general acknowledgment list of stakeholder nations and many excellent tomes on the subject, the discourse of African navigation is herein placed in the forefront.

Some of the nations are coastal States, having control directly over various vital international waterways while some nations are landlocked but also participating on the oceans as part of the international trading community and signatory members to various navigation related treaties. It is important to mention here that statistically the geographic location of an African nation in relation to the sea and port access shows that coastal nations tend to have a higher developmental growth than landlocked countries, from research provided by Africa Country Benchmark Report (ACBR) however according to the same report, there are countries such as Rwanda, Uganda and Zambia seem not to be held back by their landlocked geographical location. Exchange of ideas and sharing sound business practices which has helped these landlocked nations is possible under

the AU forum. It is clear that coastal locations and waterways has a direct impact on the development and economic success of African nations, now let us consider navigational rules.

3. NAVIGATIONAL RIGHTS OF AFRICAN STATES IN MARITIME ZONES

The study of African commitment to the conventions that regulate navigation in this paper will start with the LOSC, 1982. The LOSC, has specific navigational rights provisions for States concerning internal waters, territorial seas, rights in what is termed the Exclusive Economic Zone (EEZ) and navigational rights in the high seas, where public international law and regulation is paramount. We will look into these provisions in order to understand how these rights operate in African navigation while also considering important aspects of national security and control such as the application of Cabotage laws.

The provisions of the treaty clearly show first of all the extent to which a coastal State has control and it can be summarized as seen in Figure 2 below capturing Articles 2 to 14 of the LOSC. Many countries in the AU are not only part of the LOSC but also signatory to Part XI of the LOSC which established the International Seabed Authority (ISA) which superintends the process of exploration and exploitation of mineral resources in the 'Area' of the sea which is beyond the territorial waters of any nation but forms part of the common heritage of mankind (the high seas). Therefore, according to the LOSC treaty, this means that there is no nation that does not have an interest in the high seas since it is the common heritage of mankind. As we are discussing navigational rights of African States it is therefore essential to establish that the existence of the high seas and the laws pertaining to its navigation, exploration and exploitation also means that African navigation is not a matter that is solely and exclusively only on the shoulders of coastal States.

Article 138 of the LOSC further provides that all actions taken in the Area must bear in mind peace, justice, international interests, cooperation and understanding which means that there is no room for tolerating misuse of navigational aids, unlawful passages and other illicit conduct.

With regard to internal waters: African States who are signatory to the LOSC are guided by the spatial geography of their location of their baselines and continental shelves in terms of the guidance provided by Figure 2 above which captures the essence of the rights to control and navigation of internal waters. Article 8 is also particularly helpful in expressing the rights of

nations over their territorial waters by expressly providing that, with the exception of Part IV (which deals with the special circumstances concerning archipelagic States), ‘waters on the landward side of the baseline of the territorial sea form part of the internal waters of the State.’

Figure 2 - Illustration: Source (2021). New Zealand Environmental Guide Illustration of LOSC, 1982

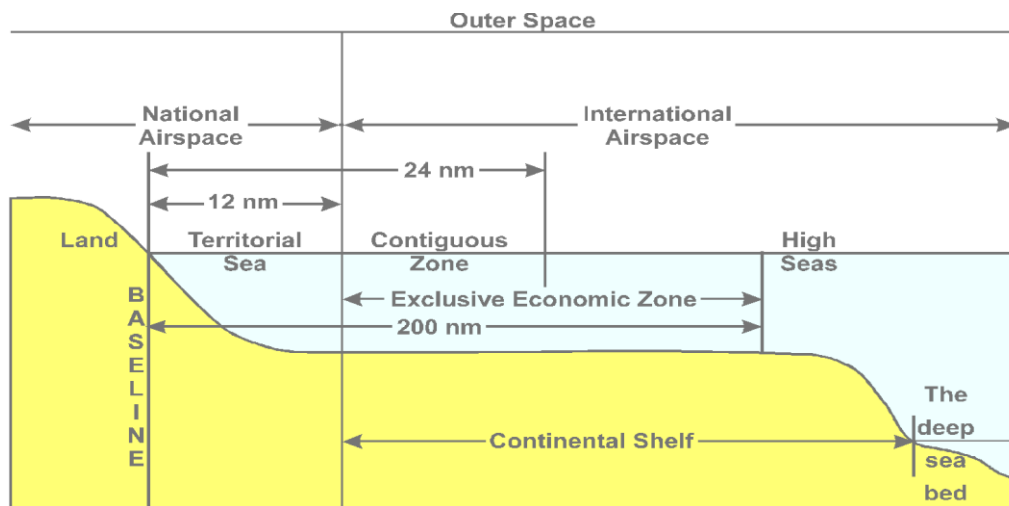

The Sovereignty of a nation over its internal waters that form part of the territory of a nation is well established within those national laws of many African States. For Example, Algeria, through its Constitution, international law and national (including customs) law exercises, ‘sovereignty over all the different areas of the maritime spaces that fall under her jurisdiction’ through the authority conferred and vested in the Wilayas (authorized political subdivisions and powers) national municipalities. Exercising powers over internal waters may take the form of making laws regarding that area, signing treaties that may impact that territory, protecting biodiversity, regulating various fishing and other types of maritime activities, maritime security and surveillance.

There are several examples of African States have adopted this approach particularly as independent modern nations who are taking charge of their own coasts and resources, see for example, Angola’s Maritime Zones Act 2010 (MZA) and the Angolan rules on ship navigation within territorial and internal waters which must comply with Angola’s rules on ship registration and the Presidential decrees on navigation promulgated in 2016. Beninese law, a further example also shows adherence to international law as captured under its Water Management Law of 2010 defining internal waters in which Benin exercises sovereignty as waters, ‘constituted by standing water and running water on the surface of the soil and ground water upstream of the baseline used for measuring the breath of territorial waters.

From these few examples of African States, we see an express involvement, representation and maritime power being exercised by the States over their own territories with a general express commitment to international law.

With regard to the territorial waters, we can say that internal waters are part of a state's territory therefore in a sense we have already established some understanding as to the power of an African State over its territorial waters. However, in order to have a sound comprehension of the language of the LOSC which goes further in defining internal waters and the general sea as demarcated or delimited by a special distance as shown in Figure 2, above. The African State which is signatory to the Convention recognized that, 'Every State has the right to establish the breadth of its territorial sea up to a limit not exceeding 12 nautical miles, measured from baselines determined in accordance with this Convention.' Articles 3 to 16 of the Convention go further to explain aspects of territorial waters such as roadsteads, reefs, ports etc., all which fall under the control of the Coastal State with a few exceptions, such as those explained in Article 15 where, for example, States have opposite or adjacent coasts. Coastal States have sovereign power over territorial waters subject to permitting rights of innocent passage over areas that have subsequently become part of territorial waters, after the application of Article 7 baselines delimitation but were not deemed to be such traditionally.

With regard to the Exclusive Economic Zone (EEZ), Figure 2 above is most helpful in creating a visual summary of what forms part on a State's EEZ. More importantly, the EEZ is defined as, 'The exclusive economic zone is an area beyond and adjacent to the territorial sea, subject to the specific legal regime established in this Part, under which the rights and jurisdiction of the coastal State and the rights and freedoms of other States are governed by the relevant provisions of this Convention.' Every African State has rights in the EEZ as described under Article 56 of the Convention, which includes, inter alia, 'sovereign rights for the purpose of exploring and exploiting, conserving and managing the natural resources, whether living or non-living, of the waters superjacent to the seabed and of the seabed and its subsoil, and with regard to other activities for the economic exploitation and exploration of the zone...' With regard to navigation, this means that African States can permit any vessels to pass through and navigate their EEZs provided such passage is done within the international comity rules of the Convention as well as giving respect to the rights of the Coastal State in exercising their article 56 rights in the EEZ.

With regard to cabotage laws, it is essential to make mention of cabotage as a practice among nations. Cabotage is a practice that is a type of protectionism as it allows the domestic market of

carriage of goods and passengers to be exclusively left to domestic companies and entities. We see this in the United States Jones Act, which provides, 'all goods transported by water between U.S. ports be carried in U.S.-flag ships, constructed in the United States, owned by U.S. citizens, and crewed by U.S. citizens and U.S. permanent residents.' In this paper the merits or demerits of this law is not the focus but that it is used as an example of showing how Cabotage works and is particularly relevant to navigation in that, an African State which does not have Cabotage will not have a protected domestic market on the use of its waterways or airways. Interestingly the State of Mauritania practices Cabotage by allowing vessels to go through the process of Mauritanisation, which means the process where the ship is conferred the right and privileges to fly the flag of Mauritania. The vessel must meet the following conditions, the vessel must be built in Mauritania or imported on a regular basis. The vessel ownership must show a majority shareholding by Mauritania nationals. What is clear is that cabotage gives these States practical sovereignty in the use of their territorial seas which can only boost navigation rights and presence on national waters.

The issue with the territorial sea as pronounced by the LOSC is that not all nations are a party to the treaty (though all nations are affected by the application of the treaty). The United States of America (USA) for example, though not a party to the LOSC due to reasons such as having to pass the treaty through Congress which can be a difficult and long process, before adoption, the USA does recognize the customary implications of the application of the LOSC.

According to the LOSC, the territorial sea of nations may produce boundary clashes of interests between nations because of the spatial geography of certain land masses and sea. These cases often end up being settled as a maritime delimitation case in an international court or the matter can be sent for arbitration at an international forum.

One of the sensitive maritime delimitation cases involved the South China Sea disputes where nations in that area, because of maritime delimitation were also having navigational problems in that area as certain vessels were simply confiscated under the suspicion of encroaching on neighboring territorial seas and finally the Philippines sought a decision.

The Philippines, launched an arbitration case against China on 22 January 2013 in *The Republic of the Philippines v The People's Republic of China* in a matter concerned with 'with respect to the dispute with China over the maritime jurisdiction of the Philippines in the West Philippine Sea.'

In this paper we are drawing special attention to the African world which also benefits from the dispute resolutions on delimitation decisions as provided for by the LOSC. This is because African countries also have competing territorial interests. Authors Ntola and Vrancken delve deeply into the area of maritime delimitation using the Eastern Seaboard of Africa as a case study demonstrating the impact of the LOSC. In the case study, the authors consider two African case studies (Eritrea v Yemen and Kenya v Somalia) and afterwards suggest practical steps as to how to approach delimitation conflicts before they are contested in the international court.

This is particularly important on matters of African navigation and the general maritime activities in disputed areas. A country that is awarded greater rights over a territory can then exercise navigational sovereignties, control and naval activity in the area, this is why decisions from the international court are essential especially since not all nations will have a simple LOSC territorial delimitation.

Since we are dealing with African States and navigational rights, another important case which was decided on by A Special Chamber of the International Tribunal for the Law of the Sea (ITLOS) involved a delimitation dispute between Ghana and Côte d'Ivoire as they disputed over an area of the territorial sea found to be rich in hydrocarbons.

The tribunal made a ruling following the strict application of the LOSC rules and the equidistance line applied in conclusion to this case ended up favoring Ghana. This does mean that with respect to navigation, Ghana would have the right to detain, question and even confiscate assets of offenders who still dare to exercise sovereign rights and navigational rights reserved for Ghana in that area.

It is submitted however that for African unity purposes these matters be dealt with in a diplomatic manner. Author, Maria Gavouneli, after deliberating on the rationale followed by the tribunal in its decision, submits that one of the great lessons we can glean from the Dispute Concerning Delimitation of the Maritime Boundary between Ghana and Côte d'Ivoire in the Atlantic Ocean (Ghana/Côte d'Ivoire) Case Number 23 is that the tribunal used a methodology and approach that can be justified to be sound following the approach of other similar cases on delimitation while respecting that some adjustments and deviation from the strict interpretation of the LOSC provisions may be called for sometimes only because of the special circumstances of those cases otherwise if there are no special circumstances, the outcome can be quite predictable as clear rules

are applied. This gives hope to nations that they will be able to control the areas that belong to them rightfully.

4. HIGHLIGHTS OF REGULATIONS AND PROCEDURES FOR PASSAGE IN AFRICAN STATE NAVIGATION PRACTICE

Representing the northern areas of the African continent, the State of Morocco which has in its regulatory archives navigational law and practice in the form of Act No. 1-81 of 18 December 1980, promulgated by Dahir No. 1-81-179 of 8 April 1981, establishing a 200-nautical-mile Exclusive Economic Zone off the Moroccan coasts (the Act) in line with the United Nations LOSC serves as a helpful starting point in sampling African State navigational. Morocco is a nation geographically close to European trade partners and having rich history with links to ancient trading cities such as Carthage long before it became modern day Tunis. With regard to freedom of navigation in Morocco Article 6 of the Act in subsection 1 permits freedom of navigation for ordinary lawful uses of the Moroccan EEZ with an explicit prohibition in subsection 2 of the Article of foreign vessels from fishing, research, pollution and any other activities that go against Moroccan maritime interests.

With regard to the innocent passage of warships, the very idea of the existence of such a right has always been blanketed with controversy. On the passage of warships, the modern LOSC created by four conventions, one of which was the Geneva Convention on the High Seas of 1958, provides in its Article 17 that, 'ships of all States...enjoy the right of innocent passage through the territorial sea,' Article 19 defines what innocent passage is and shows that it is concerned with the national interests and safety of the coastal States. The modern LOSC Article 17 however differs from the 1958 Geneva Convention which had an Article 17 and 23 which required that foreign ships had to comply with a coastal State's rules and regulations, particularly warships had to comply or they could be asked to leave the territorial waters of the coastal State. This means a coastal State under the 1958 Geneva Convention could require notification from passing warships so that the State could prepare for compliance aspects from that passing warship.

Author Shao Jin, in his article titled, 'The Question of Innocent Passage of Warships' has successfully outlined the historical trends that have influenced what the innocent of warships would look like for superpower nations when compared to countries in Latin America or African

States and showed that for countries such as Morocco and others such as Yemen, Oman and Malaysia they were in the camp of nations that fought for prior notification for warships seeking to pass innocently on their States. However, Morocco today has Law 37.17 which was adopted by its Parliament on January 22, 2020 and promulgated by Dahir on March 5, 2020 acknowledging that the sovereign rights of the State are affected and somewhat limited by the Article 17 LOSC right to innocent passage so long as such passage of course is in line with peace, good order and security of Morocco.

With regard to nuclear waste ships, the nation we could look into for highlights in regulation is South Africa, representing the Southern parts of the African continent. The problem of nuclear waste dumping and the general transportation on ships of toxic materials has been alarming. According to author, J.M. Van Dyke, 'in November 1992, Japan shipped 2,200 pounds (one metric ton) of plutonium in a refitted freighter called the Akatsuki Maru from France to Japan, going around the Cape of Good Hope in Africa and then south of Australia and New Zealand before turning north to traverse the Pacific to Japan.' The implications of mishandled nuclear waste are a major concern for African States who do not wish to become a dumping ground or an accident area. The Bamako Convention is clear about the commitment to keeping Africa States safe. In South African ship navigation practice, the law to look to, inter alia, is the Marine Traffic Act 2 of 1981, particularly the regulations section which give the minister powers to promulgate on matters of warships, nuclear waste carrying ships and any other class of ships.

The South African Marine Traffic Act of South Africa not only enforces the LOSC standards but it also provides in section 14 that, '14. (1) The Minister may make regulations— (a) regulating marine traffic in the territorial and internal waters, including the prescribing of ship reporting procedures, sea lanes and traffic separation schemes for ships in general or for any class of ship or for ships carrying nuclear or other dangerous or noxious substances;' According to the latest Government Gazette proclamation 88 No. 45536 GOVERNMENT GAZETTE, dated 26 November 2021, the South African Government is working on a specific project under various nuclear energy laws of the nation. This means for ships and ship navigation and nuclear energy, the government will also deal with this on a case by case basis while taking input and comments from the public on major projects.

Representing the North-Eastern regions of Africa, it is worth discussing Libya and the controversy of the Line of Death established by former Libyan leader Muammar Qaddafi in 1973. The Line of Death drawn in the Gulf of Sidra allowed Libya's leader to claim the entire gulf as the territory of

Libya which was against the LOSC. This led to clashes with the United States who wanted to exercise various naval drills and activities in what should be international waters. There are many lessons to be gleaned from the history and modern operations of Libyan shipping and most importantly it is clear that without a strongman to enforce the Line of Death or any other controversial territorial delimitation, this means that the enforcement of the LOSC regulations is more possible. All those navigating African coasts must be aware of these examples of regulation and be able to plan their voyages with full awareness of histories and concerns of the area being sailed through while making sure that compliance with modern peaceful rules is carefully considered. What we can learn from this period in history is that only a powerful naval force may lay claims against the LOSC.

5. THE LOSC AND AFRICAN INTERESTS

Having established that the LOSC protects the territorial seas of nations in an open and declared manner, it is critical to briefly consider whether or not, the actual language of the treaty supports the modern African world. If the language does so then it is safe to conclude that African interests are represented, African nations do have a voice and can participate meaningfully in the world economic stage. If this is found not to be happening, then the international forums are there for grievances to be heard allowing pragmatic solutions to be sought. This, of course, will take commitment from the nations themselves through their leaders and citizens. It may seem daunting but it can certainly be done. Figure 3 below shows one of the biggest challenges to maritime security and navigation around the African continent. Piracy seems to have moved from the east coast to the west coast. The fact that many AU nations are parties to the LOSC, 1982, shows that there is a commitment to eradicating threats such as piracy and armed robbery to navigational interests around African coasts.

On emphasizing the point on African challenges, author Rodrigue Akohou, on his commentary on Beninese maritime laws and the law of the sea reminds us that safety in navigation will always be a multi-faceted use of the maritime space. He shows us that like most African States, legislation seems to have done all it can to address maritime safety issues but the reality is that the serious piracy crimes that keep happening have and keep harming the nation's maritime interests particularly in 2011 and 2012 but the President of the nation did not give up but set up a strategy to deal with the enforcement of Beninese powers at sea. It is submitted that strategies of this

nature can after many years be measured through data for effectiveness so that other African States and any other nations having the same problems can adopt these strategies as well and improve individual national maritime interests.

Figure 3 - Source: International Maritime Bureau (IMB) showing piracy and armed robbery hotspots live as of 02/05/2021.

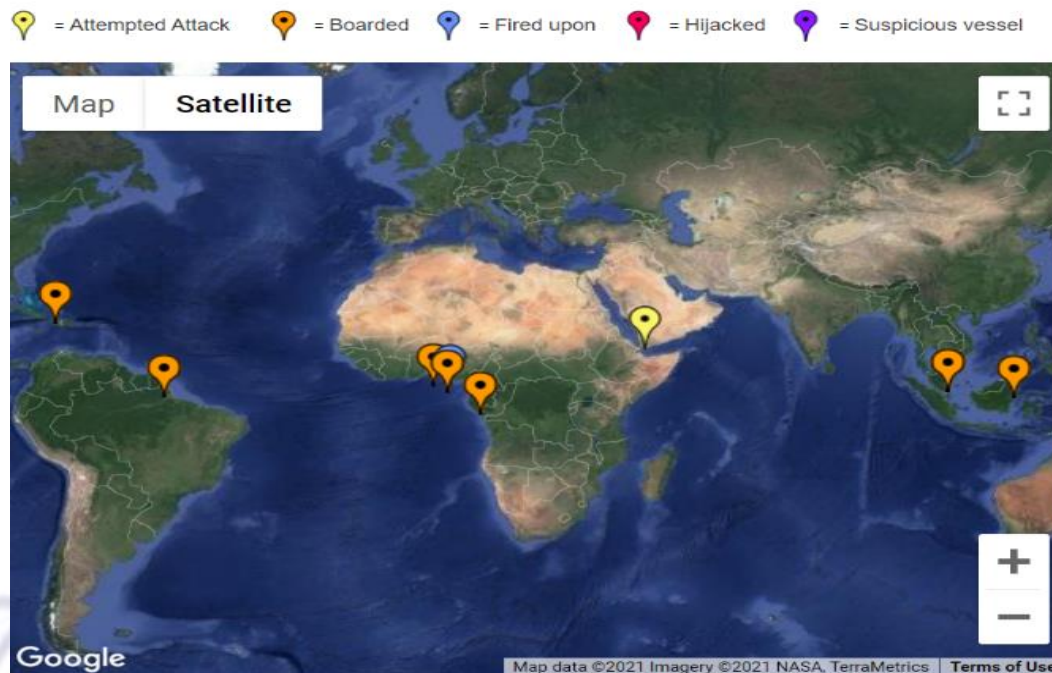

Here is clear language from the LOSC that shows commitment to supporting African nations (and all nations that have attributes to those similar to African nations) in the exercise of their maritime territorial rights and navigation. It is in many parts of the LOSC, starting with the preamble. Here are the examples of such provisions:

‘Bearing in mind that the achievement of these goals will contribute to the realization of a just and equitable international economic order which takes into account the interests and needs of mankind as a whole and, in particular, the special interests and needs of developing countries, whether coastal or land-locked,

Believing that the codification and progressive development of the law of the sea achieved in this Convention will contribute to the strengthening of peace, security, cooperation and friendly relations among all nations in conformity with the principles of justice and equal rights and will promote the economic and social advancement of all peoples of the world, in accordance with the Purposes and Principles of the United Nations as set forth in the Charter.’

On matters of research, exploration and exploitation which involves international navigation, it would appear that some African States are active, this is promising for the continent and indeed for the progress of world. We see nations such as South Africa, as an example, which safely and successfully sends a research vessel, the S.A. Agulhas II, which is an ice breaking class polar supply and research vessel. This is a successful endeavor by South Africa's government, through the Department of Environmental Affairs (DEA) among other research endeavors such as the same country's naval vessel, a new hydrographic vessel which is lauded as, 'a marvel of maritime engineering...a most sophisticated vessel to be built by a local company.' The Nigerian navy also launched its new hydrographic vessel showing yet another example of African coastal nations committing to the full development, navigation and management of their territorial seas. When research vessels are listed by country, African nations still fall behind by far, therefore there is still much development work to do in Africa, but the LOSC supports this.

6. LOSC AND AFRICAN NAVIGATIONAL RIGHTS

It is submitted that the LOSC is essentially about navigation, so it will be necessary to highlight a selected few provisions of the LOSC to unlock the spirit of this law on matters of navigation. There are various important provisions for navigation granted by the LOSC to nations such as the right of innocent passage on territorial seas of other nations as shown in articles 17 to 26 and article 45. Further provisions also include the rights to transit passage which form PART III of the treaty that deals with straits used for international navigation.

The treaty gives a special legal status to these areas and nations navigating in these areas and based in these territories must respect this special legal status. An example of innocent passage straits through African States would be for example, the Straits of Gibraltar which have a long history and practice that provides a connection between Africa and Europe.

It is submitted that ship-owners and companies using these special legal status passageways must aim to be socially responsible so that they do not have the appearance of making the nations in international passageways appear to be treated like observing by-standers while their sea territories continue to benefit what looks like powerful entities who sometimes even permanently pollute their territories. David Jones wrote a book on companies winning out of being socially responsible and since the LOSC is encouraging this for the African world, through the language

that research and development and other technical assistance given to African States in assistance should be encouraged this ideology should be explored and pragmatically applied without abusing the businesses that trade in developing States.

In other words, African States through the human resource capital, knowledge and skills development can go back to fishing (for example some African nations have had their fishing stocks depleted by foreign overfishing or pollution from the natural consequences of ship navigation, thus devastating local economies and subsistence farming), even if it is aqua fishing for example, be taught to build ships etc. so that there is this social responsibility partnership of mutual development between the business of shipping and the African States that oversee the shipping routes.

Here are the navigational freedoms and rights in the international Straits under the LOSC as provided for in Articles 37 and 38:

6.1 Article 38

'Right of Transit Passage

1. In straits referred to in article 37 (those described as 'straits which are used for international navigation between one part of the high seas or an exclusive economic zone and another part of the high seas or an exclusive economic zone. '), all ships and aircraft enjoy the right of transit passage, which shall not be impeded; except that, if the strait is formed by an island of a State bordering the strait and its mainland, transit passage shall not apply if there exists seaward of the island a route through the high seas or through an exclusive economic zone of similar convenience with respect to navigational and hydrographical characteristics.
2. Transit passage means the exercise in accordance with this Part of the freedom of navigation and overflight solely for the purpose of continuous and expeditious transit of the strait between one part of the high seas or an exclusive economic zone and another part of the high seas or an exclusive economic zone. However, the requirement of continuous and expeditious transit does not preclude passage through the strait for the purpose of entering, leaving or returning from a State bordering the strait, subject to the conditions of entry to that State.

3. Any activity which is not an exercise of the right of transit passage through a strait remains subject to the other applicable provisions of this Convention.’

Another important navigational provision relates to naval vessels as a representation of a nation’s sovereign immunity. Coastal nations in Africa have navies and the navigation rules for national security assets are well provided for under the LOSC.

‘The provisions of this Convention regarding the protection and preservation of the marine environment do not apply to any warship, naval auxiliary, other vessels or aircraft owned or operated by a State and used, for the time being, only on government non-commercial service.

However, each State shall ensure, by the adoption of appropriate measures not impairing operations or operational capabilities of such vessels or aircraft owned or operated by it, that such vessels or aircraft act in a manner consistent, so far as is reasonable and practicable, with this Convention.’

The provision above was the rule considered in the case of NML Capital Limited (Appellant) v Republic of Argentina (Respondent). In the NML case, a Cayman Island company referred to as a ‘vulture fund’ managed to secure summary judgment in terms of New York law against the Sovereign state of Argentina for defaults in the payment of government bonds and interest thereon.

This led to a subsequent naval immunity controversy when NML arrested an Argentinean naval vessel to enforce the judgment in the Ghanaian jurisdiction while the vessel was innocently invited for a military drill. However, release of the Argentine naval vessel was immediately ordered by the International Tribunal on the Law of the Sea (ITLOS) in the “ARA Libertad” Case (Argentina v Ghana).

The ITLOS made the order stating that the detention of The “ARA Libertad” Frigata was, a violation of the international obligation of respecting the immunities from jurisdiction and execution enjoyed by such vessel pursuant to article 32 of the LOSC and article 3 of the 1926 Convention for the Unification of Certain Rules concerning the Immunity of State-owned Vessels as well as pursuant to well-established general or customary international law rules in this regard; Prevents the exercise of the right to sail out of the waters subject to the jurisdiction of the coastal State and the right of freedom of navigation enjoyed by the vessel and its crew, pursuant to Articles 18, paragraph 1(b), 87, paragraph 1(a), and 90 of the LOSC.

7. DIRECT IMPACT OF TREATIES ON NAVIGATION

Navigational freedoms are granted to nations under the LOSC typically these also work directly with a number of other international rules and regulations, especially those that are ship operation related, which countries in Africa and all over the world may adopt. These rules also influence how African nations will engage with their own internal law enforcement and navigation practices over their territories.

For example, here is a list of the International Maritime Organization (IMO) treaties which are adopted by many African States. Moreover, it is imperative that these instruments must be read together with the AU's Revised African Maritime Transport Charter, 'Resolved to implement Decision N° EX.CL/Dec.358 (XI) of the Executive Council of the African Union which endorses the Abuja Declaration and Plan of Action on Maritime Transports in Africa, particularly point 1 relating to the updating of the African Maritime Transport Charter adopted in 1993.' This revised charter confirms that African States are not retreating from the position of strong commitment to the future of the African coasts.

A treaty like the COLREGS for instance, which is considered to be a very important treaty for, inter alia, collision prevention, maintenance of navigational aids, keeping safe distances and speeds, seaworthiness, all have to do with successful navigation.

Then there are treaties developed under UN agencies such as the UNCTAD and others designed to regulate private international law, such as the International Convention for the Unification of Certain Rules of Law relating to Bills of Lading ("Hague Rules"), 1924 and others like it which deal with navigation from the perspective of ship-owner liability, exonerating the ship from errors in navigation for instance.

Then there's issues of navigation pertaining to vessels being permitted to enter or not enter certain ports because of the types of fuels they burn. For example, Emission Controlled Area (ECA) ports strictly do not permit certain fuels to be burned in their port limits and therefore a ship that is perfectly seaworthy may be prevented from navigating in ECA areas if it does not have compliant fuel or some technology on board to manage its SO_x and NO_x emissions, Sulphur and Nitrogen oxides respectively.

8. CONCLUSION

With navigation being a sensitive balance between many rules and regulations from an international and national perspective, it is clear that an African State must not only read into the AU maritime strategies on smooth and economically viable navigation but prepare to work towards reaching the highest goals in navigation management in order to position its own economy for the blue economy. Here are some recommended best practices.

An African State whether coastal or landlocked must have a strong government based Maritime or Shipping Authority that is highly active in organizations that create national and international law as well as participates in discussions on creating and adopting international law. This should not be left to big costal economies like South Africa, Kenya, and Nigeria to name just three examples.

If one studies landlocked countries like Botswana, Zimbabwe and Zambia, they do, to a limited extent, sign treaties that affect shipping, thus showing interest in the sea territory and may one day as a nation invest in the exploration and exploitation of The Area of the oceans and benefit their local economies. The theme that 'a nation still benefits and can further benefit from the sea without living next to the sea' is something that should be explored as a partnership between States in the AU to take advantage of all the LOSC supported research, educational, economic activity that is proposed as the future for the African coasts.

Other best practices is for AU nations to cooperate with one another and the international community to deal not only with suppressing crimes at sea and in ports but to actually invest in looking at actual source causes for maritime crimes so that that maliferous culture can be changed at the source. Successful economies can build successful individuals and families and thus discourage crimes.

Further, States in Africa should look at all the business activities of shipping and invest in those that have the greatest return and sustainability for their special situations. Because of shipping cycles and the dynamic nature of the global economy, mega-size ship ownership is not the only way that an African State can be successful in the maritime industry but it can be one of the businesses. What is important is that whatever business is engaged in the maritime sector must involve practices that will keep the navigation of vessels operating successfully and all international obligations of signatory parties to various treaties properly met. Finally, nations in

the AU should consider short-sea shipping and the use of inland waterways as a way to boost local economies in those regions. There are many statisticians and economists that can team up to make some of these proposals a reality.

Notes/Thanks/Other declarations (Conflict of Interest Declaration)

To the future of the oceans and all the children of the earth being supported by it. A special thanks to industry and research representatives who granted me interviews and literature to learn more about their involvement in navigational policies and maritime strategy for the African continent. The author declares that the writings in this paper were research based and the author does not represent any conflicting special affiliations nor is there any conflict of interest. The information shared here is also in the public domain herein synthesized to give educational, strategic and visionary inspiration with an intense focus on international regulatory compliance tools for readers.

REFERENCES

Abou J. Peacebuilding in the African Union: Law, Philosophy and Practice (2012) 24 and 36.

African Union (AU) 'Celebration of African Day of Seas and Oceans and meeting of the Strategic Task Force on 2050 Africa's Integrated Maritime Strategy (AIM 2050) – 30 and 31 May 2018 – Addis Ababa, Ethiopia' (30.05.2018), available at <https://au.int/en/speeches/20180530/statement-amb-dr-namira-negm-legal-counsel-african-union-commission> (accessed: 02.03.2023).

African Union (AU) 'Member States' (2021) available at <https://au.int/memberstates> (accessed: 01.11.2020).

African Union (AU) 'Member States' (2021) available at <https://au.int/memberstates> (accessed: 01.11.2020).

African Union (AU) 'Member States' (2021) on matters of nonpayment of member dues see AU provisions available at <https://au.int/en/pressreleases/20181127/african-union-strengthens-its-sanction-regime-non-payment-dues> (accessed 08.26.2022).

African Union (AU) 'Member States' (2021), available at <https://au.int/memberstates> (accessed: 10.08.2022).

African Union (AU) 'Member States' (2021), available at <https://au.int/memberstates> (accessed: 10.08.2022).

African Union (AU) Article 4(a) of the Constitutive Act of the African Union (2158 UNTS 3, (2005) 13 AJICL 25; adopted: 11.07.2000; EIF: 26.05.2001).

African Union (AU) Revised Maritime Transport Charter (2021), available at <https://www.peaceau.org/uploads/revised-african-maritime-transport-charter-en.pdf> (accessed 08.29.2022).

Bamako Convention on the Ban of the Import into Africa and the Control of Transboundary Movement and Management of Hazardous Wastes within Africa, 1998.

Ben-Ari N. 'Piracy in West Africa' (2021), available at <https://www.un.org/africarenewal/magazine/december-2013/piracy-west-africa> (accessed: 02.05.2022).

Clarksons Research 'Shipping intelligence network' (2021), available at <https://sin.clarksons.net/> (accessed: 29.07.2022).

Convention on the International Regulations for Preventing Collisions at Sea (COLREG), 1972.

De Oliveira J.M. 'Angola' Law of the Sea, Unpublished Manuscript (2017). 23; 33.

DefenceWeb 'South African navy's new hydrographic survey vessel' (2021), available at <https://defense.info/partners-corner/2020/06/south-african-navys-new-hydrographic-survey-vessel/> (accessed: 02.01.2022).

Duncan E.J.; Currie J.; Van Dyke M. (2005) Recent Developments in the International Law Governing Shipments of Nuclear Materials and Wastes and their Implications for SIDS. Review of European Community and International Environmental Law 14:2, pages 117-124.

Emission Control Areas (ECA), 'Latest Ports Lists' (2021), available at <https://www.totalubmarine.com/faq/technical/what-are-latest-eca-zone-regulations> (accessed: 08.29.2022).

Environment Guide 'Areas' (2021), available at <http://www.environmentguide.org.nz/issues/marine/marine-management/areas/> (accessed: 02.01.2022).

Ford J.; Wilcox C. 'Shedding light on the dark side of maritime trade – A new approach for identifying countries as flags of convenience' (2019) 99 MP 298–303.

Gavouneli M. 'Delimiting delimitation: Lessons learned from the ITLOS Chamber Judgment on the dispute concerning delimitation of the maritime boundary between Ghana and Côte d'Ivoire in the Atlantic Ocean', available at https://www.researchgate.net/publication/320794560_Delimiting_Delimitation_Lessons_Learned_from_the_ITLOS_Chamber_Judgment_on_the_Dispute_Concerning_Delimitation_of_the_Maritime_Boundary_between_Ghana_and_Cote_DDIvoire_in_the_Atlantic_Ocean (accessed: 08.29.2022).

IMB Piracy & Armed Robbery Map (2021), available at <https://www.icc-ccs.org/piracy-reporting-centre/live-piracy-map> (accessed 04.28.23).

In on Africa (IOA) 'Africa's landlocked countries' perpetual disadvantage' (24.08.2017), available at <https://www.inonafrika.com/2017/08/24/africas-landlocked-countries-perpetual-disadvantage/> (accessed: 02.01.2022).

International Convention for The Unification Of Certain Rules Of Law Relating To Bills Of Lading, Hague-Visby Rules, 1968 Article IV '2.

International Court of Justice Maritime delimitation in the Indian Ocean (Somalia v. Kenya) (2021). This matter is still ongoing. Available at <https://www.icj-cij.org/public/files/case-related/161/161-20200522-PRE-01-00-EN.pdf> (accessed: 02.05.2022).

International Tribunal for the Law of the Sea (ITLOS) 'Dispute concerning delimitation of the maritime boundary between Ghana and Côte d'Ivoire in the Atlantic Ocean (Ghana/Côte d'Ivoire) Case Number 23' (2021), available at <https://www.itlos.org/cases/list-of-cases/case-no-23/> (accessed: 09.12.2020).

International Tribunal for the Law of the Sea Order of 15 December (2012), ITLOS Reports 2012 at 335 <https://www.itlos.org/en/main/cases/list-of-cases/> (accessed: 10.08.2022).

International Tribunal for the Law of the Sea Order of 15 December (2012), ITLOS Reports 2012 at 340 <https://www.itlos.org/en/main/cases/list-of-cases/> (accessed: 10.08.2022).

Jones D. 'Who Cares Wins: Why Good Business is Better Business' (2011).

Jules C.; Vrancken P. 'Mauritania' The Law of The Sea, Unpublished Manuscript (2017) 134.

Kerdoun A. 'Algeria' Law of the Sea, Unpublished Manuscript (2017) 1.

Kerdoun A. 'Algeria' Law of the Sea, Unpublished Manuscript (2017) 1.

Korten D.C. 'Sustainability and the global economy: Beyond Bretton Woods' (15.11.2010), available at <https://davidkorten.org/bretton/> (accessed: 29.07.2022).

Lawrence W. Kaye, 'The Innocent Passage of Warships in Foreign Territorial Seas: A Threatened Legal Information Relevant to the United Nations Convention on the Law of the Sea.' *Law of the Sea Bulletin*, vol. 59, (2006) 15.

Lawrence W. Kaye, *The Innocent Passage of Warships in Foreign Territorial Seas: A Threatened Freedom*, 15 *SAN DIEGO L. REV.* 573 (1978) 577 - 578.

List of research vessels by country: <https://amti.csis.org/a-survey-of-marine-research-vessels-in-the-indo-pacific/> (accessed: 08.29.2022).

NML Capital Limited (Appellant) v Republic of Argentina (Respondent) [2011] UKSC 31 at 2.

NML Capital Limited (Appellant) v Republic of Argentina (Respondent) [2011] UKSC 31 on appeal from [2010] EWCA Civ 41.

Ntola S.Y.; Vrancken P.H.G. 'The delimitation of maritime boundaries on Africa's eastern seaboard' (2016) 1 *JOLGA* 54–104.

Ocea 'A new hydrographic vessel for Nigeria' (2021), available at <https://www.ocea-ssm.com/ocea-new-hydrographic-research-vessel-nigeria> (accessed: 02.01.2022).

Ouguergouz F.; Yusuf A. 'The African Union Legal and Institutional Framework: A Manual on the Pan-African Organization' (2012) 20-23.

Permanent Court of Arbitration, 'Eritrea/Yemen - Sovereignty and Maritime Delimitation in the Red Sea (2021), available at <https://pca-cpa.org/en/cases/81/> (accessed: 10.08.2022).

Problems of illegal fishing which is nearly impossible to manage without strong legal enforcement: <https://www.un.org/africarenewal/magazine/may-july-2017/overfishing-destroying-livelihoods> (accessed 08.29.2022).

R Akohou 'Benin' Law of the Sea, Unpublished Manuscript (2017) 40, 49, 56, 65.

Ratifications by States to determine the number of African nations that have adopted these rules available at See IMO 'Status of Conventions' (2021), available at <https://www.imo.org/en/About/Conventions/Pages/StatusOfConventions.aspx> (accessed: 02.02.2022).

Roche B. 'Stuff We Should All Know' (2021) 314 United Kingdom, Page Publishing Incorporated.

Ruys T. 'The Meaning of "Force" and the Boundaries of the Jus Ad Bellum: Are "Minimal" Uses of Force Excluded from UN Charter Article 2(4)?' *The American Journal of International Law*, vol. 108, no. 2, 2014, pp. 184.

Shao Jin, 'The Question of Innocent Passage of Warships: After UNCLOS III,' *Marine Policy*, Volume 13, Issue 1, 1989, Pages 56-67.

Ship Technology 'Polar supply and research vessel, South Africa' (2021), available at <https://www.ship-technology.com/projects/polarsupplyandresearch/> (accessed: 02.05.2022).

United Nations Conference on Trade and Development (UNCTAD) 'Prosperity for all' (2021), available at <https://unctad.org/> (accessed: on 02.04.2022).

United Nations Conference on Trade and Development (UNCTAD) Maritime Profile of landlocked State, Botswana, available at <https://unctadstat.unctad.org/countryprofile/MaritimeProfile/en-GB/072/index.html> (accessed 08.29.2022).

United Nations Convention on the Law of the Sea, 1982, Article 236 of the LOSC. UN General Assembly, Convention on the Law of the Sea, 10 December 1982, available at: <https://www.refworld.org/docid/3dd8fd1b4.html> [accessed 28 April 2023] 1833 UNTS 3, (1982) 21 ILM 1261. Adopted: 10.12.1982; EIF: 16.11.1994.

United Nations Convention on the Law of the Sea, 1982, Article 236 of the LOSC. UN General Assembly, Convention on the Law of the Sea, 10 December 1982, available at: <https://www.refworld.org/docid/3dd8fd1b4.html> [accessed 28 April 2023]. Section 3. Technical Assistance. Article 202.

United Nations Convention on the Law of the Sea, 1982, Article 236 of the LOSC. UN General Assembly, Convention on the Law of the Sea, 10 December 1982, available at: <https://www.refworld.org/docid/3dd8fd1b4.html> [accessed 28 April 2023]

Van Dyke J.M. 'Transit Passage Through International Straits' (2008) 33.

William S. (Sir.) 'New Classical Dictionary of Biography, Mythology and Geography,' (1850) 371 New York, Harper Brothers.

Wu X. 'Maritime delimitation in the Indian Ocean (Somalia v. Kenya), judgment on preliminary objections' (2018) 17 *Chinese Journal of International Law* 841–860.

AUTHORS



Dr. Fikile Portia Ndlovu is a distinguished Professor of International Maritime Business, Lawyer, Author, and Speaker from Durban, South Africa. She specializes in maritime law and international trade, with a focus on environmental law, maritime security, and mining of sea areas. Dr. Ndlovu has published numerous books and articles on these topics, including her latest book on ballast water management. She is also a consultant for government bodies and commercial entities and has served as an arbitrator in various tribunals.

TOWARDS A HARMONIZED APPROACH: UNDERSTANDING DATA SOURCES FOR MARINE INCIDENT AND ACCIDENT ANALYSIS

Dr Poonam Kapoor¹, Ms Yogyata Kapoor² & Mr Abdullah Siddique³.

Abstract

Marine incidents and accidents are a major concern in the shipping industry, with significant implications for human safety, the environment, and the global economy. Understanding the causes and consequences of these incidents is critical to improving the safety and efficiency of maritime transportation. The paper provides an overview of the various data sources available for the study of marine incidents and accidents, it also discusses the strengths and limitations of each data source and highlights the challenges associated with integrating and analysing data from multiple sources. The paper concludes by suggesting that a harmonized and standardized approach to data collection and reporting could facilitate more effective analysis of marine incidents and accidents and enable the development of targeted risk mitigation strategies.

Keywords: Marine incidents, accidents, data sources, International Maritime Organization, GISIS, national accident investigation bodies, industry-specific organizations, data integration, risk mitigation.

1. INTRODUCTION

Maritime transport plays a critical role in global trade and commerce, with over 90% of world trade being carried by sea. However, this mode of transportation is not without risk, and incidents and accidents involving ships, crew, and cargo can have serious consequences for human safety, the environment, and the economy.

¹ Director of ISF Group, Founder of Inner Search Foundation, and has worked extensively as a professional counsellor.

Email: poonamkapoor@isfgroup.in

² Director of Global Marketing & Business Development at ISF Group & Convener of IMRC (International Maritime Research Confluence).

Email: yogyatakapoor@isfgroup.in

³ Research Consultant at ISF Group under the Division of IIRE, Inner Search Foundation.

Email: abdullahsiddique07@gmail.com

The study of marine incidents and accidents is therefore essential to ensure the safe and efficient operation of the shipping industry and to mitigate the negative impacts of such incidents.

Various organizations collect data on marine incidents and accidents, including the International Maritime Organization (IMO) through its Global Integrated Shipping Information System (GISIS), national accident investigation bodies, and industry-specific organizations. Each data source has its strengths and limitations, and a comprehensive analysis of marine incidents and accidents requires the integration of multiple data sources.

This paper provides an overview of the various data sources available for the study of marine incidents and accidents. It discusses the strengths and limitations of each data source, and highlights the challenges associated with integrating and analysing data from multiple sources. The paper also presents case studies to illustrate the importance of a multi-source approach in the analysis of marine incidents and accidents.

The paper concludes by emphasizing the importance of collaboration between different stakeholders in the maritime industry to improve the quality and availability of data on marine incidents and accidents.

It suggests that a harmonized and standardized approach to data collection and reporting could facilitate more effective analysis of marine incidents and accidents and enable the development of targeted risk mitigation strategies.

2. LITERATURE REVIEW:

Analysing accident statistics is crucial in assessing the risks involved in marine transportation. Such analysis reveals that different types of vessels are susceptible to distinct kinds of casualties. To gain a general understanding of accident data, an article by (Milioris Konstantinos, 2015) analysed a database compiled from information from the Ministry of Shipping and the Aegean, Directorate of Ship Safety. The article used descriptive statistical methods and hypothesis tests to examine the relationship between the vessel type parameter and variables such as accident responsibility, accident result, and accident location. Further insights were derived by investigating the relationship between a total loss event and ship age. By exploring the major

factors behind marine disasters, decision-makers can take necessary measures to improve maritime safety (Miloris Konstantinos, 2015)

The International Maritime Organization (IMO) describes the shipping industry as "perhaps the most internationalized of the world's great businesses, and one of the most dangerous" (Faulkner, 2002). Over the past few decades, there has been a significant increase in vessel size and population.

To develop a comprehensive database of ship casualties, Toffoli et al. utilized the Lloyd's Marine Information Service (LMIS) and compiled information on 650 incidents that occurred between January 1995 and April 1999. The database included all recorded incidents that caused damage to seagoing merchant ships with gross tonnages of 100 or more.

While there are many studies on marine safety that focus on individual ship incidents across the world, the analysis of marine disasters has become a popular research topic (A. Toffoli, 2006).

The Norwegian Maritime Directorate (NMD) published casualty data that categorized documented accidents into various groups, including fire/explosion, grounding, heavy weather, capsize, collision, contact, leaking, pollution/environmental damage, personnel-related, missing, and other causes (Norwegian Maritime Directorate, 2009).

Similarly, the LRFP accident database (February 1997 to February 2007) also divided accidents into different groups, including foundered, wrecked/stranded, contact, collision, fire and explosion, missing, war loss/damage during hostilities, hull/machinery damage, and other incidents (LRFP (March Version), 2008).

. According to Faulkner, there are two primary causes of vessel destruction or loss. Design and maintenance issues, such as water intrusion, hull breaking in two, and capsizing, account for approximately 40% of incidents, while operational reasons like fire, collision, and machinery damage make up the remaining 60% (Faulkner, 2002).

Despite some incidents being caused by human error, unforeseen circumstances and hazardous sea conditions can make it challenging to maintain proper control of the ship. The UK's Marine Accident Investigation Branch (MAIB) notes that "human error" drives the majority of maritime accidents (Committee on Environment, 2000).

In New Zealand, 49% of maritime mishaps are attributed to human causes, compared to 35% attributed to mechanical issues and 16% to environmental factors (Willem A. Wagenaar, 1987).

An intriguing study has found that 74 passenger ship maritime catastrophes occurred in Greek seas between 1992 and 2005, and around 65% of them were due to human inadequacies. Between 1992 and 2005, 13% of all maritime incidents involving Greek-flagged ships were passenger vessels. A passenger vessel's age is not related to the cause of a maritime catastrophe, but its size may be. Smaller vessels are more vulnerable to accidents due to inadequate human factors.

It is worth noting that 14 out of 15 marine catastrophes involving passenger vessels with collision as the first incident were blamed on human error. This is significant because, between 1992 and 2005, collision incidents accounted for 78 out of the total 95 fatalities and injuries, including 80 deaths and 3 injuries.

Over 65% of passenger vessel incidents between 1992 and 2005 were attributed to human error. The frequency of catastrophes is highest for vessels between the ages of 21 and 25, with a decrease in incidents for vessels above the age of 25.

However, the age of the passenger vessel did not correlate with the cause of the catastrophe. Accidents involving human factors are more common in vessels with lesser tonnage (100–5000 GRT), whereas accidents from other causes appear to be more common on larger vessels exceeding 10,000 GRT (Gemelos J., 2006).

The study by Tzannatos analysed the causes of incidents affecting Greek-flagged vessels globally from 1993 to 2006. The research discovered that a significant proportion of catastrophes (57.1%) were caused by human error or violation, with 75.8% of these incidents identified onboard. The majority of the onboard human-induced mishaps (80.4%) were found to be related to the vessel's master's mistakes and violations (Tzannatos, 2010).

The study also revealed that younger ships (less than 9 years old) had the lowest incidence of accidents (9.7%). Groundings were the primary cause of damage for all vessel types, but technical failures and subsequent fires and explosions were also significant factors, particularly for tankers and Ro-Pax boats.

The age of the ship was linked to the breadth and intricacy of the technologies and the inherent weaknesses of cargo/passenger capacity in the above-mentioned vessel classes, resulting in ageing structural and machinery breakdowns.

Between 1993 and 2006, 57.1% of the incidents were attributed to Human Factors, while Uncertain Causes, Acts of God, and Unexpected Occurrences accounted for 31.1%, 7.9%, and 3.9%, respectively. In addition, the majority of incidents involving humans were found to be caused by people onboard (78.5%), compared to incidents involving humans onshore (12.6%) and incidents involving humans onboard and offshore (combined: 8.9%).

Despite a significant decrease in human-caused incidents following the enactment of the ISM Code in the middle of 1998, human error continues to be the leading cause of incidents, according to the study.

3. UNDERSTANDING MARINE INCIDENT AND ACCIDENT

Before we examine various data sources available for marine incidents and accidents, it is important to understand what marine incident accident and casualty is.

A marine incident or accident refers to any unexpected event that occurs during marine operations, including but not limited to shipping, fishing, and offshore activities, that results in harm to people, property, or the environment. Examples of marine incidents and accidents include collisions between vessels, groundings, capsizings, fires, explosions, oil spills, and injuries or fatalities of crew or passengers. The severity of a marine incident or accident can range from minor incidents with no or minimal consequences to major disasters with significant human, environmental, and economic impacts.

A marine casualty means an event, or a sequence of events, that has resulted in any of the following which has occurred directly in connection with the operations of the ship:

1. The death of, or serious injury to, a person.
2. The loss of a person from a ship.
3. The loss presumed loss or abandonment of a ship.

4. Material damage to a ship.
5. The stranding or disabling of a ship, or the involvement of a ship in a collision.
6. Material damage to marine infrastructure external to a ship, that could seriously endanger the safety of the ship, another ship or an individual; or
7. Severe damage to the environment, or the potential for severe damage to the environment, brought about by the damage of a ship or ships.

However, a marine casualty does not include a deliberate act or omission with the intention to cause harm to the safety of a ship, an individual or the environment.

For studying and analysing marine incidents and accidents, it is important to consider a range of data sources to obtain a comprehensive understanding of the issue. The most reliable and useful data sources will depend on the specific research question and context. Some of the key data sources for marine incidents and accidents are:

3.1 The International Maritime Organization's Global Integrated Shipping Information System (IMO GISIS)

IMO GISIS plays an essential role in collecting data on marine incidents and accidents. It is a web-based platform used by IMO Member States to report and share information on maritime matters, including accidents and incidents.

IMO GISIS collects data on a wide range of maritime incidents and accidents, including collisions, groundings, capsizings, fires, and pollution incidents. The data collected includes the type of incident, location, vessel details, casualties, and damage to the environment.

All IMO Member States are encouraged to report incidents and accidents to IMO GISIS, and many countries actively participate in reporting such events. As of September 2021, 172 Member States had submitted data to IMO GISIS, covering incidents and accidents that occurred within their respective jurisdictions or involving their vessels.

The data available with IMO GISIS is not limited to incidents and accidents occurring in a particular region or country. It represents a global view of maritime incidents and accidents, making it an invaluable resource for identifying trends and developing measures to improve

maritime safety and environmental protection. All the member State of the IMO and are encouraged to report incidents and accidents to IMO GISIS.

IMO GISIS has following parameters for reporting data on marine accidents:

1. Date, time, and location of the incident.
2. Details of the vessel(s) involved, including name, type, flag, and ownership.
3. Details of the personnel on board, including crew and passengers, and any injuries or fatalities.
4. Circumstances leading up to the incident, including weather and sea conditions.
5. Damage to vessels and property, and any environmental impact.
6. Actions taken to mitigate the effects of the incident, including search and rescue, firefighting, and pollution prevention measures.
7. Details of any investigations conducted or planned, including who will be responsible for the investigation.
8. Any relevant documents or evidence related to the incident, such as logbooks, photographs, and witness statements.
9. Any relevant national or international regulations or guidelines that may have been violated.

There is a standard format for above parameters to ensure consistency and comparability of data across different countries and regions. There are several challenges faced by IMO GISIS in collecting, analysing, and sharing data on marine incidents and accidents. Some of these challenges include:

Incomplete or inaccurate data: One of the biggest challenges faced by GISIS is incomplete or inaccurate data provided by Member States. This can hinder the analysis of trends and development of measures to enhance maritime safety and environmental protection.

Limited participation: Although GISIS is open to all IMO Member States, not all countries actively participate in reporting incidents and accidents. This can result in an incomplete and biased picture of global maritime safety and environmental protection.

Lack of standardization: There is a lack of standardization in reporting formats and data collection methods among Member States, which can make it difficult to compare and analyze data across different countries and regions. This can result in data inconsistencies and hinder efforts to develop effective measures to enhance maritime safety and environmental protection.

Cybersecurity threats: As a web-based platform, IMO GISIS is vulnerable to cybersecurity threats, including data breaches and cyberattacks, which can compromise the security and integrity of the data.

To address these challenges, IMO GISIS can take several steps, including:

Enhancing data quality: GISIS can work with Member States to improve the completeness and accuracy of data submitted to the system. This can involve providing technical assistance and training to Member States on reporting requirements and data collection methods.

Encouraging participation: GISIS can work to encourage more Member States to actively participate in reporting incidents and accidents. This can involve outreach and awareness-raising activities to highlight the benefits of reporting incidents and accidents to the system.

Standardizing reporting formats: GISIS can work with Member States to develop and implement standard reporting formats and data collection methods. This can help to ensure consistency and comparability of data across different countries and regions.

Strengthening cybersecurity measures: GISIS can implement robust cybersecurity measures, including regular security audits and training for users, to help protect the system from cyber threats and maintain the security and integrity of the data.

IMO also recognizes the importance of capacity-building and technical assistance for developing nations to help them meet their obligations under the IMO instruments, including the reporting of incidents and accidents. Therefore, the IMO provides technical assistance and capacity-building programs to support developing nations in fulfilling their reporting obligations and improving their maritime safety and environmental protection capabilities.

3.2 European Maritime Safety Agency (EMSA):

EMSA is an agency of the European Union that provides technical, operational, and scientific assistance to the EU Member States in the field of maritime safety. The agency collects and reports data on maritime incidents and accidents occurring within the EU waters. The EU's maritime safety policies by providing technical assistance, training, and coordination of maritime surveillance and response operations. EMSA operates several systems and services to collect and disseminate data on maritime safety and environmental protection, such as Clean Sea Net, oil spill detection system, Safe Sea Net, vessel traffic monitoring and information system. Here are the strengths of the data collected and reported by EMSA:

Standardized reporting: EMSA collects data using standardized reporting procedures and formats, which enable easy comparison and analysis of data across different regions and time periods.

Timeliness: EMSA provides regular updates on maritime incidents and accidents, which can be useful for early warning and risk assessment purposes.

Comprehensive coverage: EMSA covers all types of incidents and accidents, including pollution, vessel groundings, collisions, and fatalities, providing a broad picture of the safety situation in EU waters.

High data quality: EMSA ensures the accuracy and reliability of the data it collects, by verifying the data with the responsible authorities and using advanced data processing and quality control methods.

Limitations of the data collected and reported by EMSA:

Limited geographical scope: EMSA only covers incidents and accidents within the EU waters, which may not provide a complete picture of the global trends in maritime safety.

Limited depth: EMSA's data does not provide detailed analysis of the contributing factors or root causes of incidents and accidents, which can limit the ability to identify underlying issues and develop effective safety measures.

Limited accessibility: The EMSA data is available primarily to the EU Member States and may not be easily accessible to the public or non-EU stakeholders.

Reporting bias: The data collected by EMSA may be subject to reporting biases, as it relies on voluntary reporting by the responsible authorities, which may not report all incidents or accidents. EMSA's data collection and reporting procedures have several strengths, including standardized reporting and comprehensive coverage, but it also has its limitations, including a limited geographical scope and limited depth of analysis. Overall, EMSA's data can be a valuable source of information for assessing maritime safety in the EU waters, but it is important to consider these limitations when analysing the data.

3.3 National accident investigation bodies:

National accident investigation bodies are responsible for investigating and reporting on marine incidents and accidents within their respective jurisdictions.

Below are some of National accident investigation bodies:

1. National Transportation Safety Board (NTSB) - United States
2. Marine Accident Investigation Branch (MAIB) - United Kingdom
3. Transportation Safety Board of Canada (TSB) - Canada
4. Australian Transport Safety Bureau (ATSB) - Australia
5. Bundesstelle für Seeunfalluntersuchung (BSU) - Germany
6. Japan Transport Safety Board (JTSB) - Japan
7. Korea Marine Accident Investigation Board (KMAIB) - South Korea
8. Danish Maritime Accident Investigation Board (DMAIB) - Denmark
9. Accident Investigation Board Norway (AIBN) - Norway
10. Maritime New Zealand (MNZ) - New Zealand

National Accident Investigation Body	Strengths	Weaknesses
National Transportation Safety Board (NTSB)	- Well-established and independent authority with broad investigative powers	Limited jurisdiction over international waters

National Accident Investigation Body	Strengths	Weaknesses
Marine Accident Investigation Branch (MAIB)	- High level of expertise in marine accident investigations	
Transportation Safety Board of Canada (TSB)	- Excellent reputation for thorough and impartial investigations	
Australian Transport Safety Bureau (ATSB)	- Highly experienced and skilled investigators with strong technical capabilities	
Bundesstelle für Seeunfalluntersuchung (BSU)	- Strong technical expertise in marine accident investigations	
Japan Transport Safety Board (JTSB)	- Highly experienced investigators with expertise in marine technology and regulations	
Korea Marine Accident Investigation Board (KMAIB)	- High level of technical expertise in marine accident investigations	
Danish Maritime Accident Investigation Board (DMAIB)	- Experienced and well-trained investigators with a focus on safety culture	
Accident Investigation Board Norway (AIBN)	- High standard of technical expertise in marine accident investigations	
Maritime New Zealand (MNZ)	- Strong focus on safety and risk management	

The data from national accident investigation body valuable for analysing regional trends and contributing factors,

Comprehensive investigations: National accident investigation bodies conduct comprehensive investigations that analyse various factors contributing to marine incidents and accidents, such as human factors, environmental conditions, and equipment failures.

Access to first-hand information: These bodies have access to first-hand information, including data from the vessel's black box, eyewitness accounts, and data from the vessel's voyage data recorder.

Detailed reports: National accident investigation bodies provide detailed reports on incidents that can be used to inform policy decisions and improve safety measures in the maritime industry.

Independent oversight: These bodies are typically independent from the maritime industry, which can provide unbiased oversight of incidents and ensure accountability.

3.4 Weaknesses:

Limited scope: National accident investigation bodies only investigate incidents within their jurisdiction, which may not provide a complete picture of global trends in marine incidents and accidents.

Variations in reporting standards: Different national bodies may have different reporting standards, making it difficult to compare and analyse data across different regions.

Limited availability: Data from these bodies may not be readily available to the public, or may only be available in the local language, which can limit its accessibility for global analysis.

Lack of standardization: National accident investigation bodies may not follow a standardized reporting format or methodology, making it difficult to compare and aggregate data from different regions.

In conclusion, while data from national accident investigation bodies can provide valuable insights into regional trends and contributing factors of marine incidents and accidents, their limitations must also be considered when analysing data on a global scale. A multi-source approach that integrates data from multiple organizations and regions can provide a more comprehensive and representative analysis of global trends in marine incidents and accidents.

4. INDUSTRY REPORTS AND STATISTICS

Here are some of the noteworthy industry reports publishing data on marine incidents and accidents:

1. Lloyd's List Intelligence Casualty Statistics
2. International Chamber of Shipping Annual Review of Maritime Losses and Casualties
3. Allianz Global Corporate & Specialty Safety and Shipping Review
4. Marine Accident Investigation Branch (MAIB) Annual Report

5. Oil Companies International Marine Forum (OCIMF) Annual Report on Marine Incidents
6. International Union of Marine Insurance (IUMI) Statistical Report
7. International Maritime Bureau (IMB) Piracy and Armed Robbery Report
8. United Nations Conference on Trade and Development (UNCTAD) Review of Maritime Transport.
9. International Maritime Bureau (IMB) Annual Reports: The IMB publishes an annual report on piracy and armed robbery, as well as one on maritime crime and incidents. These reports provide information on the frequency and location of incidents, as well as details on the type of vessel and cargo involved.
10. Lloyd's List Intelligence Casualty Statistics: Lloyd's List Intelligence publishes a quarterly report on shipping casualties and incidents, which includes information on vessel losses, crew injuries, and pollution incidents.
11. Safety4Sea: Safety4Sea is an online platform that provides news and information on safety and sustainability in the shipping industry. They also publish an annual report on maritime safety, which includes statistics and analysis on accidents and incidents.
12. Marine Accident Investigation Branch (MAIB) Annual Reports: The MAIB publishes an annual report on marine accidents and incidents in UK waters, which provides details on the causes and circumstances of accidents, as well as recommendations for improving safety.
13. National Oceanic and Atmospheric Administration (NOAA) Reports: The NOAA publishes reports on marine incidents and accidents in US waters, including oil spills, vessel groundings, and other incidents.

5. COMPARATIVE ANALYSIS OF THE STRENGTHS AND LIMITATIONS OF VARIOUS REPORT ON MARINE INCIDENTS AND ACCIDENTS⁴

Report	Strengths	Limitations
Lloyd's List Intelligence Casualty Reports	Provides comprehensive and timely data	Limited to incidents involving ships over 100 gross tons
IHS Markit Safety at Sea	Provides detailed analysis and insights	Limited to incidents involving ships over 500 gross tons
International Chamber of Shipping	Provides aggregated data from multiple sources	Limited to incidents involving ships over 100 gross tons
Allianz Global Corporate & Specialty	Provides insights into trends and emerging risks	Limited to incidents covered by the insurance company
UK P&I Club	Provides detailed case studies and analysis	Limited to incidents involving ships insured by the club
National Cargo Bureau	Provides data on cargo-related incidents and accidents	Limited to incidents involving cargo

⁴: This table provides a general comparison and does not encompass all strengths and limitations of each report/publication.

Report	Strengths	Limitations
Marine Accident and Investigation Branch	Provides independent and thorough accident investigation	Limited to incidents occurring in UK waters
US Coast Guard	Provides comprehensive data on incidents in US waters	Limited to incidents occurring in US waters
IHS Markit Safety at Sea	Covers both shipping and offshore industries	Limited availability of some data, such as piracy incidents
Lloyd's List Intelligence Casualty Statistics	Covers all major vessel types	Limited to data on vessel casualties and does not include data on smaller incidents or near-misses
Allianz Global Corporate & Specialty Safety and Shipping Review	Provides in-depth analysis of trends and root causes	Limited availability of data on smaller incidents or near-misses, only covers incidents involving insured vessels
International Chamber of Shipping Annual Safety Report	Provides insights into industry initiatives and progress	Limited availability of data on smaller incidents or near-misses, limited to incidents involving ICS member vessels

Report	Strengths	Limitations
International Union of Marine Insurance Statistics Report	Covers both commercial and leisure vessels	Limited availability of data on smaller incidents or near-misses, limited to incidents involving insured vessels, may not include all incidents
UK Marine Accident Investigation Branch Annual Report	Provides detailed analysis of individual incidents	Limited to incidents occurring in UK waters, may not include all incidents, limited to incidents investigated by the MAIB
European Maritime Safety Agency Annual Overview of Marine Casualties and Incidents	Covers all types of vessels and incidents	Limited availability of data on some incidents, may not include all incidents, limited to incidents occurring in European waters

Each of these reports and publications provides unique insights and perspectives on marine incidents and accidents and can be used to supplement and enhance the data provided by national accident investigation bodies and other sources.

5.1 Academic research and studies:

Academic research and studies on marine incidents and accidents:

1. "The Costs of Maritime Piracy" by Peter Chalk and Laurence Smallman (2013)
2. "Safety Culture in the Maritime Industry" by Andrew R. Hiles (2012)
3. "Human Error in the Maritime Industry: An Overview of Mare-Human Factors Guidelines and Their Limitations" by M. Baldauf and K. Wijnolst (2011)

4. "A Quantitative Analysis of Maritime Piracy and Its Economic Consequences" by Vítor Hugo Fernandes and José Pedro Santos (2014)
5. "Risk Management in the Maritime Industry" by Yashar Jarrar and Andrew Hiles (2010)
6. "Human Factors in the Maritime Domain: Analysis of Accidents in Shipping and Fishing" by Eleni Konstantinou and Eirik Albrechtsen (2018)
7. "Measuring and Enhancing Resilience in Maritime Transportation Systems" by Luca Urciuoli and Birgit Mager (2018)

It's worth noting that these studies may have different focuses and methodologies, and their strengths and limitations may depend on various factors such as the sample size, data sources, and analytical techniques used.

6. COMPARATIVE ANALYSIS OF STRENGTHS AND LIMITATIONS OF VARIOUS ACADEMIC RESEARCH

Academic Research Study	Strengths	Limitations
"Analysis of maritime accidents and their causes in Turkey" by Huseyin Onay and Ozan Durmus	Provides a detailed analysis of the causes of maritime accidents in Turkey	Limited to the Turkish maritime industry
"Factors contributing to shipping accidents: The human element" by Helen Thanopoulou	Focuses on the human element in shipping accidents, providing insights into crew behaviour and decision-making	Limited to the human element and does not provide a comprehensive analysis of all contributing factors

Academic Research Study	Strengths	Limitations
"A review of ship accidents and incidents caused by navigation errors" by G. Rong and X. Shi	Provides a detailed analysis of navigation errors leading to ship accidents and incidents	Limited to navigation errors and does not provide a comprehensive analysis of all contributing factors
"A review of major shipping accidents in the Chinese Yangtze River Delta" by Xuefei Zhou and Weiwei Wu	Provides a detailed analysis of major shipping accidents in the Chinese Yangtze River Delta	Limited to the Chinese maritime industry and the Yangtze River Delta region
"Analysis of the causes of shipping accidents in the Korean peninsula" by Jae-Gu Song and Yong-Su Kwon	Provides a detailed analysis of the causes of shipping accidents in the Korean peninsula	Limited to the Korean maritime industry
"Factors affecting the frequency and severity of maritime accidents: The case of the Mediterranean Sea" by Christos Lemonakis and Eleni A. Gekara	Provides a comprehensive analysis of the factors affecting the frequency and severity of maritime accidents in the Mediterranean Sea	Limited to the Mediterranean Sea region
"Marine accident analysis: A review and some new developments" by Pentti Kujala and Risto Lahdelma	Provides a review of existing methods for marine accident analysis and proposes new developments	Focuses on methodological issues and does not provide a detailed analysis of specific accidents or incidents
"Analysis of maritime accidents using a system theoretic approach" by Pradeep Kumar and Srinivasan Chandrasekaran	Proposes a system theoretic approach to analyse maritime accidents, providing a new analytical framework	Focuses on methodological issues and does not provide a detailed analysis of specific accidents or incidents

It is important to note that each of these academic research studies has its own unique strengths and limitations, and they can be used in combination with other sources of data and analysis to gain a more comprehensive understanding of marine incidents and accidents.

6.1 News and media:

News and media reports are also a useful source of information for identifying emerging issues and trends industry experiences. These may not always provide a complete or accurate picture of incidents, however, an important medium to refer. There are several news and media outlets that provide coverage of marine incidents and accidents. Some of the most prominent ones are Lloyd's List, TradeWinds, MarineLink, Safety at Sea, and Seatrade Maritime News etc.

News and media outlets can provide valuable information on marine incidents and accidents, their coverage may not always be comprehensive or completely accurate. It's important to verify information and consider multiple sources when conducting research on this topic.

6.2 Challenges of integrating and analyzing data from multiple sources:

Integrating and analyzing data from multiple sources available for marine incidents and accidents can be a challenging task due to the following reasons:

1. **Data inconsistencies:** Data from different sources may have inconsistencies, such as different units of measurement, different reporting periods, and different data structures. This can make it difficult to integrate the data and compare it across different sources.
2. **Data quality:** The quality of data from different sources may vary, depending on the data collection methods, accuracy of the data, and completeness of the data. Incomplete or inaccurate data can lead to misleading conclusions.
3. **Data privacy:** Data protection and privacy laws may restrict the sharing of data between different organizations, which can limit the availability of data for analysis.
4. **Data standardization:** The lack of common standards for data collection and reporting can make it difficult to integrate data from different sources. Different organizations

may use different definitions for incidents and accidents, which can lead to confusion and errors when comparing data.

5. Technical challenges: Integrating and analyzing large volumes of data from multiple sources can require significant computing power and technical expertise, which may be beyond the resources of some organizations.
6. Cultural differences: Different organizations may have different approaches to data collection and reporting, which can be influenced by cultural and organizational factors. These differences can make it difficult to align data from different sources.

To address these challenges, it is essential to establish common standards for data collection and reporting, promote data sharing and collaboration among different organizations, and invest in data integration and analysis tools and techniques. It is also important to recognize the limitations of the data and consider multiple sources when analysing marine incidents and accidents.

7. CONCLUSION

Marine incidents and accidents have multiple data sources and the most reliable and useful sources of data for studying marine incidents and accidents will depend on the specific needs, research question and context. It is also important to critically evaluate the quality and reliability of each data source to ensure that the information used in the analysis is accurate and reliable. It is also advisable to consider multiple sources of data to obtain a comprehensive understanding of the issue. Combining data from various sources can help provide a comprehensive understanding of marine incidents and accidents complete and will also give a reliable picture of the patterns and trends.

Studying data from various sources is very challenging as these have differences in reporting standards, data collection methodologies, and data sharing practices.

Ideally industry must have a standardize data collection and reporting procedures, so that data can be easily integrated from different sources. The development of a Common Reporting Format (CRF) should be considered. Another approach is to use advanced data analytics techniques to extract insights from the data, despite its heterogeneity. This involves identifying common

patterns, trends, and contributing factors across different incidents and accidents. By combining these approaches, it may be possible to identify gaps in safety standards and develop targeted interventions to reduce the occurrence of marine incidents and accidents.

REFERENCES

A. Toffoli, J. L.-G. (2006). *Towards the identification of warning criteria: Analysis of a ship accident database*. Applied Ocean Research.

Avtandil A Kordzadze, D. D. (2018). Pollution of the Black Sea by Oil Products. Its Monitoring and Forecasting. *Journal of the Georgian Geophysical Society*, 47 – 60.

Committee on Environment, T. a. (2000). *EXPLANATORY MEMORANDUM ON THE DEPARTMENT OF THE ENVIRONMENT TRANSPORT AND THE REGIONS ANNUAL REPORT 2000*.

Erik Hollnagel, D. D. (2006). *Resilience Engineering - Concepts and Precepts*.

European Maritime Safety Agency (EMSA). (n.d.). *Accident Investigation*.

Faulkner, D. (2002). *Shipping Safety – A Matter Of Concern*.

Gemelos J. (2006). *Human Factors and participation in maritime accidents Challenge for Passenger Ships in the Hellenic Marine Area - Statistical Models and Approach to Human Error Probability*.

Govt of UK, M. A. (n.d.).

Haddon Jr, W. (1980). The changing approach to the epidemiology, prevention, and amelioration of trauma: the transition to approaches etiologically rather than descriptively based. *American Journal of Public Health*, 70(21), 401-404.

Hollnagel, E. (2012). *FRAM: The Functional Resonance Analysis Method*. CRC Press.

International Association of Classification Societies. (n.d.). *IACS Annual Review*.

International Chamber of Shipping. (n.d.). *Shipping Industry Flag State Performance Table*.

International Maritime Organisation. (n.d.). *Implementation of Instruments Support - Casualty Statistics*.

ITOPF. (2023). *Handbook 23/24*.

Justyna Rogowska, J. N. (2010). Environmental implications of oil spills from shipping accidents. *Rev Environ Contam Toxicol*, 95-114.

LRFP (March Version). (2008). Lloyd's Register FairPlay Casualty Database .

Milioris Konstantinos, S. N. (2015). *Data analysis on maritime accidents over 1000 grt: The case of Greece*. In book: Proceedings of ICQQMEAS 2015 International Conference.

National Transportation Safety Board (NTSB). (n.d.). *Marine Accident Reports*.

Norwegian Maritime Directorate. (2009). *Report on safety measures - for anchor handling vessels and mobile offshore units*.

Parcell, R. G. (2018). An evaluation of the Swiss Cheese Model of accident causation in maritime safety. *WMU Journal of Maritime Affairs Vol 17 No.2*, 313-333.

Reason, J. (1997). *Managing the Risks of Organizational Accidents*. 272.

Reniers, G. A. (2011). Maritime transport risk analysis: Review and analysis of accident models for risk assessment of shipping. *Safety Science 49(6)*, 764-777.

Tzannatos, E. (2010). Human Element and Accidents in Greek Shipping. *Journal of Navigation*, 119 - 127.

Van Gelder, P. H. (2010). The Bow Tie Method--A Review. *Safety Science*, 554-562.

Wiegmann, D. A. (2003). A human error approach to aviation accident analysis: The human factors analysis and classification system. *Ashgate Publishing*.

Willem A. Wagenaar, J. G. (1987). Accidents at Sea: Multiple Causes and Impossible Consequences. *International Journal of Man-Machine Studies*, 587-598.

Wu, Q. &. (2019). Application of Tripod Beta model in accident analysis of ships. *Journal of Marine Science and Engineering*, 7(8), 261.

Yin, R. K. (2003). *Case Study Research: Design and Methods*. SAGE, 2003 - Social Science.

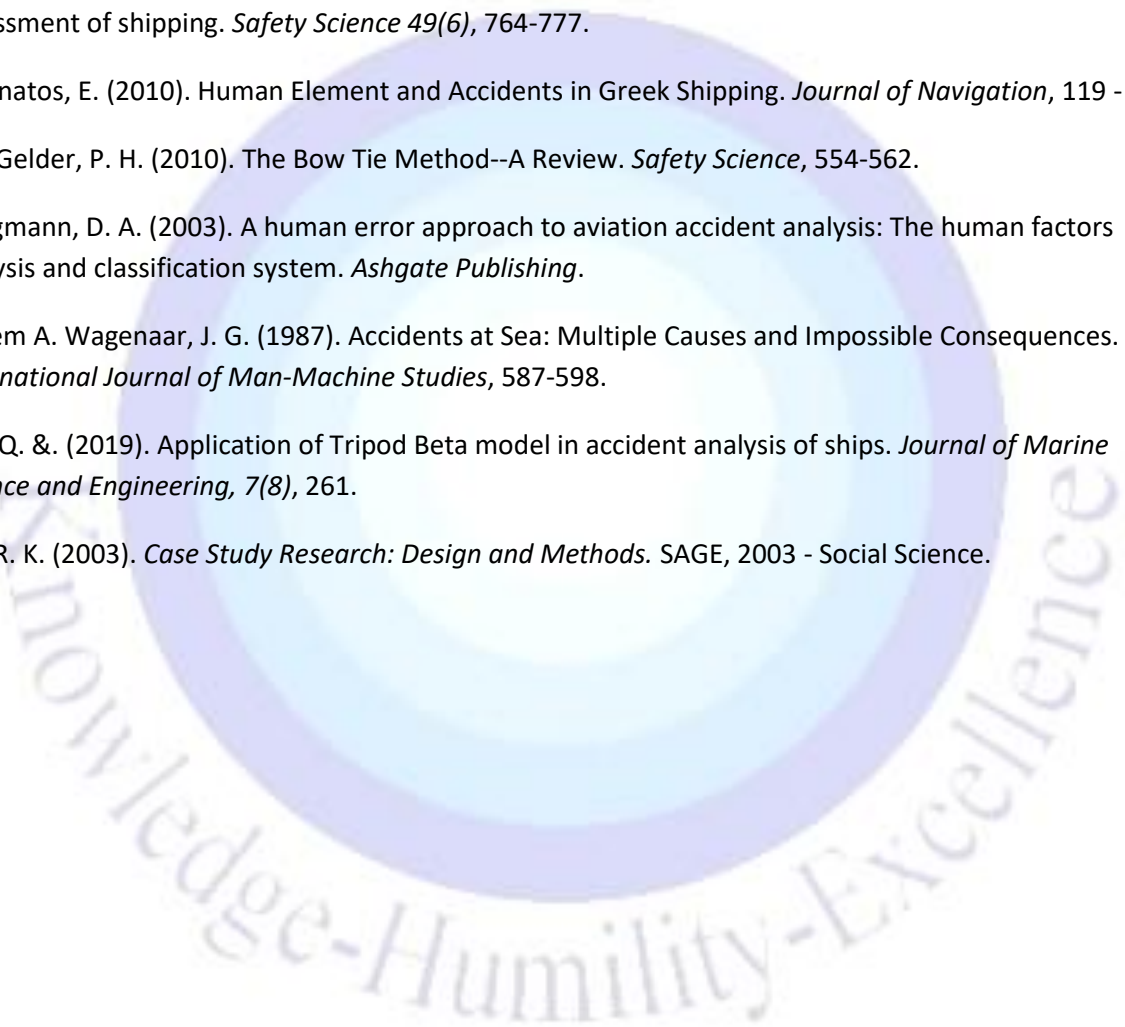

AUTHORS



Dr. Poonam Kapoor, Ph.D., is an expert in Economics, specializing in International Trade in Services and Maritime Transport Services. She is also a professional counsellor, specializing in helping seafarers and cadets. Dr. Kapoor is the co-founder of ISF Group and director of ISF Maritime Services Pvt. Ltd. Additionally, she is the co-founder and president of the Inner Search Foundation, a charitable organization promoting yoga and wellness. Dr. Kapoor is currently developing 'The Confluence', a center for yoga sciences and sustainability in Maharashtra.



Yogyata Kapoor is Director of Global Marketing & Business Development at ISF Group & Convener of IMRC (International Maritime Research Confluence).



Abdullah Siddique is designated as Research Consultant at ISF Group under the Division of IIRE, Inner Search Foundation.

STRUCTURAL ENGINEERING CHALLENGES IN A MODU TO MOPU CONVERSION PROJECT

Mr Thomas Stephen, Ms Neethu Narayanan, Mr Tomin Mathew.

Abstract

A drilling rig is often chosen by the decision makers for a Mobile Offshore Drilling Unit (MODU) to Mobile Offshore Production Unit (MOPU) conversion project without having a proper pre-purchase engineering study to verify the suitability of the rig for the MOPU project. This decision is often governed by the purchase value of the drilling rig for conversion and the maximum operation limitations of the drilling rig as specified by the Marine Operation Manual (MOM) of the drilling rig. This could lead to severe engineering challenges during the project execution which require unusual remedial actions or sometimes even abandoning the project. In this paper, a detailed discussion is presented particularly with regards to the structural engineering aspects of a MODU to MOPU conversion project.

Keywords: Overturning Stability, Pinion Stiffness, Jack Up Rig, Mobile Offshore Drilling Unit (MODU), Mobile Offshore Production Unit (MOPU), Dynamic Amplification Factor (DAF).

1. INTRODUCTION

Converting a mobile offshore drilling unit to a production installation can be a cost-effective approach for the development of offshore fields especially for the marginal field where the operational life of the field is only a few years usually less than 10 years. One of the reasons for introducing a MOPU instead of a fixed offshore platform is because, the fixed platform is generally having a design life of 25 years and it is an immobile structure whereas the MOPU can be later deployed to a different site/project with minimum modification.

2. WEIGHT CONTROL ENGINEERING

Usually, a 3-legged drilling rig is chosen for MODU to MOPU conversions. Items such as Cantilever, Drill floor, Derrick Structure, Drilling equipment etc are removed from the drilling rig

and process equipment required for the MOPU operation are added on to the main deck of the rig. One or two flare booms are also installed on to the side of the rig based on the project requirements. A gangway is connected to the nearby wellhead jacket, if any.

Weight control engineering is the prime and most important exercise that must be done with great accuracy in the FEED design itself for the smooth execution of the project. It is always beneficial to reduce the weight as much as possible for the MOPU. But this may not be possible all the time depends on the project requirement. Apart from the weight, the COG locations of the weights are crucial so as not to overload any of the legs in elevated conditions. Significant offset of COG from leg's centroid would need additional permanent ballast to correct COG which will further increase the overall weight which would directly affects the jacking system capacity and dynamics of the MOPU and thus wave excitation forces.

3. SITE SPECIFIC MET-OCEAN CONDITIONS

Usually drilling rigs are not designed for any particular site-specific environment as it is expected to operate in any part of the globe. Often a standard environment condition is chosen for the basic design of the drilling. For North Sea condition the standard environment conditions may look like below,

Maximum Wave Height: 13.5m, Wave Period: 15s

Current Velocity @ Surface: 1 knot, Current Velocity @ Seabed: 0 knots

Storm Wind Speed: 100 knots

However, when the same drilling rig must be deployed on to a particular site for the MOPU operations, the site-specific environmental loadings will come into play. Common scenarios are given below,

1. A lesser wave height, however, the wave period lies close to the natural period of MOPU which means more dynamic excitation.
2. A higher current velocity at location both at surface and at seabed. The average current speed for the original design is only 0.5 knots. However, sometimes the average current

velocity could be as high as 1.5 knots or even more. This will imply that the current loading will be 9 times the original design loading as the current velocity is 3 times more. The dynamic amplification for MOPU is to be considered for a loading condition where both wave and current loads are present and therefore this current load will be further multiplied by the dynamic amplification factor (DAF).

3. Wind loads in the same order or lesser. However, because of the windage area might be increased because of the presence of process equipment on the main deck, flare booms, extra leg length above jacking system etc. This need to be considered in the revised analysis.

4. SOIL CONDITIONS AT INSTALLATION LOCATION

Drillings rigs are never designed for any soil data. During basic design of the rig, usually a 3m penetration is considered for the design and legs are assumed to be pinned at this penetration for the global leg in-place analysis.

However, when the vessel is deployed to a particular location for MOPU operation, the site-specific analysis is to be carried out to ensure that the vessel can be safely operated at the location. One of the important parameters is the soil strength at installation location.

If the soil strength is comparatively low, then the legs and spudcan would experience more penetration. This directly implies that the usable leg length is reduced by excessive penetration. For example, in Indonesian waters, a typical drilling rig designed for North Sea conditions (3m penetration) would have a penetration of more than 25m as the soil is very weak. So, the usable leg length is reduced by at least 22m compared to the original design.

5. DYNAMIC AMPLIFICATION FACTOR (DAF)

When a jack-up vessel is subjected to wave loading, it is subjected to dynamic excitation. The degree of the excitation depends on the natural frequency and the incident wave period. If they are close together, resonance might occur. In the basic design a standard wave period of 15s is used for the assessment.

The drilling rig's natural frequency may lie in the range of 5s in the storm loading condition as the rig normally has reduced weight for storm survival by reducing variable loads on board. Since the natural frequency and the wave incident frequency are far away, the DAF will be very less in the drilling rig design.

When it comes to the MOPU loading conditions, it has less freedom to reduce weight during storm case unlike drilling rig variable loads.

The weight of the MOPU stays almost the same during operational and storm cases. Therefore, MOPU has increased weight in storm condition and therefore the natural time period for MOPU in storm condition would shift towards 7s to 8s in some cases.

Apart from the shift in natural frequency, the incident wave period will be based on the actual met-ocean condition. Usually, each directional wave has different wave periods and heights as per the site-specific data.

Some of these wave periods might come close to the natural frequency of the structure which could cause DAF to be a much larger value which would directly amplify Wave and Current loading drastically which would result in structural failures.

6. VARIABLE LOADS

A drilling rig has the flexibility to reduce the variable load to move on to storm survival mode which would directly reduce the loads on to the legs, spudcan and jacking system and reduce the natural period of the rig which would further reduce the wave excitation forces.

But for a MOPU, the weight remains almost constant regardless of whether it is a 1 year operational environment or 100 year storm environment.

Therefore, the natural time period will be on a higher side and the wave excitation would be higher.

7. JACKING SYSTEM LIMITATIONS (PINION CAPACITIES)

Jacking system is specified with storm, operating, jacking and preload capacities for the drilling rig. Any of the loadings, weights, COG shifts mentioned above are towards unfavourable side, then this would result in jacking system failure which is generally indicated by the pinion ratings. There are chances that the pinion capacities exceed in either of these cases.

8. MARINE GROWTH & HYDRODYNAMIC COEFFICIENTS

In a drilling rig design, the basic designer usually does not consider any marine growth and consider that the leg members are always smooth. But when it comes to a MOPU design, a marine growth needs to be considered as per the project specification which would automatically increase the diameter of the legs members and thus attract more loads. Moreover, the hydrodynamic coefficients for the leg members will be changed from smooth to rough. For example, drag coefficient for smooth cylinder is 0.65 whereas it is 1.05 for rough cylinder. That is a 62% direct increase in drag force only because of the change from smooth to rough.

9. GLOBAL HULL STRENGTH & GLOBAL LEG STRENGTH

In general, because of the increase in loadings as specified in the above sections, the global strength of the vessel and the global in-place analysis need to be re-verified for the anticipated loading conditions. Often, the jacking structure might also need to be re-verified for these additional loadings.

10. CONCLUSION

There are other aspects of the MODU to MOPU conversion projects. But only the structural engineering problems are discussed in this paper.

It often happens that the project owner is deceived by the capacities & specifications listed in the approved operation manual of a drilling rig while choosing a drilling rig for the MODU to MOPU conversion. If a proper, pre-purchase engineering is carried out to check the suitability of the rig for conversion, it could lead to a disaster during the execution of the project.

REFERENCES

SNAME Guidelines for Site Specific Assessment of Mobile Jack-Up Units, August 2008

ABS Rules for Building & Classing Mobile Offshore Units, Jan 2023

API RP 2A – WSD Planning, Designing, and Constructing Fixed Offshore Platforms—Working Stress Design, 22nd Edition.

AUTHORS



Thomas holds a dual degree in Naval Architecture and Ocean Engineering from IIT Madras. After completing degree in 2011, he worked with GL Noble Denton, DNV GL and ODL Engineering until he co-founded Ark2tech in 2016. Ark2tech is into FEED, Detail and Advanced Engineering consultancy services in Marine, Offshore & Oil/Gas Domains.



Neethu holds a B Tech degree in Civil Engineering from NIT Calicut. After completing degree in 2010, she worked with L & T Valdel & Lamprell until she co-founded Ark2tech in 2016. Neethu is proficient in structural engineering for Steel Structures, Fixed Offshore Platforms and Jack-up Vessels.



Tomin graduated from Toc H Institute of Science and Technology, Kerala and passed out in the year of 2019. He started his career with Ark2Tech as a structural engineer and picked up his skills in steel structure design, Finite Element Analysis and Offshore Structural Designs for Fixed and Mobile Platforms.

MENTAL AND EMOTIONAL WELL-BEING

Dr Poonam Kapoor¹.

Abstract

Working in the Merchant Navy can be rewarding, but also demanding. Seafarers face unique challenges that can affect their mental and emotional health, such as isolation, stress, fatigue, and culture shock. To deal with these challenges effectively, seafarers need to be mentally and emotionally prepared before and during their voyage. This article highlights the need for such preparation, not only for the youngsters but also to experienced officers and crew members on board.

Keywords: Merchant Navy, Seafarers, Mental health, Emotional health, Well-being, Work performance, Interpersonal relationships.

1. INTRODUCTION

The Merchant Navy is a vital part of global trade and offers attractive career prospects for individuals. It involves extensive travel, exposure to diverse culture, high pay, tax-free income, and chances to visit new places, makes it a desirable option for many. However, it also comes with challenges, some of them are:

1. Spending long periods away from friends and family,
2. Having limited social and recreational activities with peers,
3. Continuous studies and need to clear various written and oral examinations from time to time,
4. Facing risky and dangerous situations like piracy, storms, accidents, fires, etc,

¹ Director of ISF Group, Founder of Inner Search Foundation, and has worked extensively as a professional counsellor.

Email: poonamkapoor@isfgroup.in

5. Clearing medical fitness requirements and certain criteria of physical health.

Like any other career, the merchant navy has its benefits and challenges. To work in any department of the merchant navy, one has to complete specific education and training, and pass the selection processes of the employer company. This ensures that the seafarer has the necessary education, knowledge, and skill for a certain rank on board a ship. However, the industry still faces problems related to the mental and emotional well-being of its sailing staff. The industry needs to improve its preparedness to deal with the wellbeing issues of seafarers. It is vital for every seafarer to have sound mental and emotional health, and to be ready mentally and emotionally before joining a vessel. The biggest advantage of using battery and motors instead of Internal Combustion Engines is the high efficiency of power conversion from electric to mechanical through the electric motor. Secondly, the need to reduce carbon footprint has encouraged governments to support and subsidize EVs rather than conventional IC Engine driven vehicles.

2. MENTAL AND EMOTIONAL HEALTH:

Before we go further, let us understand what mental health and emotional health mean. They refer to the well-being of a person's psychological and emotional state. They are influenced by many factors, such as thoughts, feelings, emotions, behaviours, and social interactions. Mental health covers the cognitive and behavioural aspects of a person's mental state. It includes various conditions, from depression, anxiety, to normal changes in mood, stress, and rational function. Emotional health covers the ability of a person to understand, recognize, and manage his/her emotions in a healthy and appropriate way. It involves being aware of one's emotions, regulating and expressing them in a way that does not harm oneself or others. Mental and emotional wellbeing are related concepts that affect how we feel, think, react and act. Both are interconnected and important for overall well-being. A person's mental and emotional health can affect his/her physical health, relationships, and quality of life. It can also affect an individual's performance and productivity at work. Let us examine how and why mental and emotional health play such crucial role in a professional life of a person:

1. **Performance and Productivity:** When a person is mentally and emotionally balanced, he/she is better able to focus, think critically, and make sound decisions, translating into motivation, engagement, innovation, and higher productivity.
2. **Resilience and Stress Management:** A healthy mental and emotional state can enhance an individual's ability to cope with stress and setbacks in the workplace. It helps them bounce back from challenges, adapt to changes, and maintain a positive outlook. This prevents burnout, reduce absenteeism, and promote overall well-being in a professional setting.
3. **Interpersonal Relationships:** Mental and emotional health also influence a person ability to interacts. A state of mental and emotional well-being leads to better communication, collaboration, and conflict resolutions, which are essential for positive and effective interpersonal relationships in any work setting.
4. **Decision Making and Problem Solving:** Sound mental and emotional health gives an ability to avoid impulsive or irrational reactions and gives an ability to look for solutions in difficult situation. With the mental and emotional wellbeing comes ability to think critically, consider different perspectives, and make a thoughtful decision.

3. SOURCES OF STRESS AND ANXIETY FOR SEAFARERS: UNDERSTANDING THE CHALLENGES ON BOARD A SHIP:

Joining the Merchant Navy means being away from family, friends, and comfort zone for extended periods, which brings feelings of homesickness and isolation. This can lead to various psychological challenges such as stress, depression, and anxiety (Bhatia et al., 2019; Roberts & Marlow, 2016). Studies have shown that voyage duration, job demands, job satisfaction and turnover intentions, can significantly impact the mental well-being of seafarers (Hansen & Jensen, 2017; Kalantonis & Bohlmann, 2016; Lee & Cho, 2017).

Interpersonal issues on board, communication gaps, and stressful situations at home can also increase the anxiety and stress of seafarers. A young cadet may feel disillusioned on board a vessel as his perception of life on board is different than what he or she experiences. Some more issues faced by sea fearers on board a ship can be listed as follows:

1. **Workload and work-life balance:** Maintaining a healthy work-life balance can be challenging for sailing staff on board ships. Balancing work responsibilities with personal time and recreational activities can be difficult, leading to stress and reduced job satisfaction.
2. **Working hours and fatigue:** Sailing staff on board ships often work long hours, sometimes there may be exceeding the standard working hours, which can lead to fatigue and in some cases may impact their performance, and well-being.
3. **Crew dynamics:** Living and working in close quarters with a diverse crew can sometimes lead to conflicts, differences in opinions, and personality clashes.
4. **Career development and growth opportunities:** Limited career growth prospects and monotony on board a ship may sometimes impact the motivation and job satisfaction.
5. **Uncertainty about signing off:** This can be a significant source of stress for seafaring personnel. Seafarers may experience uncertainty about when they will be able to sign off due to contract extensions or delays in crew changes. This can disrupt their plans and personal commitments and create stress and anxiety.
6. **The stigma:** The stigma associated with mental health also pose challenges. Seafarers may hesitate to seek help due to fear of repercussions, such as losing their job or being seen as unfit for duty. This can hinder their access to counselling and support services, leading to untreated mental health issues.
7. **Weather Conditions:** Adverse weather conditions, like too much rolling, pitching or storm makes life on board challenging.
8. **Gap in the level of competency:** Sailing staff require continuous training and development to maintain their competency and comply with industry regulations. Non availability of adequate training resources, opportunities for skill enhancement, and recognition of their expertise can impact their job satisfaction and performance.
9. **Access to information and communication:** Clear communication channels and access to relevant information are essential for sailing staff to perform their duties effectively. Challenges related to language barriers, communication breakdowns, and limited access to up-to-date information can cause confusion and anxiety.

4. FACTORS ADDING STRESS AND ANXIETY TO SAILING STAFF ON BOARD A SHIP:

In today's digital age, internet and connectivity have become an integral part of our lives, including the maritime industry. With the advent of satellite communications, sailors on merchant ships have access to the internet, allowing them to stay connected with their families and friends back home. However, while internet and connectivity offer numerous benefits, it also impacts the mental and emotional health of sailors at sea. It has been experienced that internet and connectivity aboard ships sometimes create additional stress and challenges for sailors, rather than providing a balance between work and personal life. The constant need to be connected impede the ability to unwind and disconnect from stressors. Additionally, connectivity brings some other issues such as:

1. **Information Overload:** With the internet readily available, sailors are bombarded with news, social media updates, and other information from the outside world. This constant stream of information can create feelings of overwhelm and anxiety, as sailors may be exposed to negative news or personal issues from home that they are unable to address while at sea. This information overload can contribute to heightened stress and emotional distress among sailors, affecting their mental well-being.
2. **Social Isolation:** Paradoxically, despite being connected to the virtual world, sailors may experience social isolation onboard. The reliance on virtual communication may not fully substitute for face-to-face interactions with loved ones, leading to feelings of loneliness, homesickness, and disconnection from social support networks. This sense of isolation can have a significant impact on the mental and emotional health of sailors, contributing to feelings of depression and anxiety.
3. **Distractions and Negative Influences:** Internet and connectivity can also expose sailors to various distractions and negative influences. Access to social media, online gaming, and other online activities can consume valuable time and attention, affecting sailors' focus on work, sleep, and self-care. Moreover, exposure to online negativity, cyberbullying, or other harmful content can further contribute to stress and emotional distress among sailors.
4. **Reduced Social Interaction among Sailing Officers:** Before the boom of internet sailing officers and crew used to engage in group activities and interactions in smoke rooms and other common areas, which helped them cope with the stress and loneliness of their

profession. However, with the advent of personal devices that provide internet access, sailing officers now have their own means of entertainment and communication which has considerably reduced time and opportunity for social interaction among seafarers. Resulting in aloofness, which increases the chances of depression and anxiety.

Clearly the constant connectivity creates challenges in achieving a healthy work-life balance for seafarers on board. It is essential to acknowledge and address the potential impact of internet and connectivity on the mental and emotional health of seafarers.

We all know that in the realm of technical troubleshooting, it is often said that knowing the problem is key to finding the solution. However, when it comes to human resources (HR) issues, simply knowing the problem is never enough. In HR, understanding the issue is crucial, but it is just the first step in a complex and multifaceted process. HR issues involve people and their emotions, perceptions, and motivations, which adds layers of complexity, and it requires more than just knowledge to navigate effectively. Unlike technical problems, HR issues often involve interpersonal dynamics, communication challenges, and diverse perspectives. They may be rooted in deep-seated beliefs, biases, or cultural norms, making them intricate and sensitive to handle. Merely knowing the issue won't necessarily lead to resolution; it's just the tip of the iceberg.

5. HUMAN RESOURCE MANAGEMENT IN SHIPPING INDUSTRY:

Human resource management (HRM) is the process of managing people and their work within an organization, it involves planning, acquiring, developing, motivating, and retaining employees to achieve organizational goals. HRM in the shipping industry is challenging and complex. The shipping industry is dynamic in nature, and it operates in a global and competitive environment. In the industry various companies may employ seafarers from different countries and cultures, who have different expectations and preferences, this coupled with the need to spend long periods out at sea, away from their families and social networks creates issues of isolation, stress, and anxiety. In addition to these issues HRM in shipping also deals with the issues related to health, and safety for seafarers. HRM faces challenges because of shortages of qualified seafarers for certain ranks, high turnover rates, and lack of skilled personnel etc. The process of recruitment, retention, and career development, training requires attention to every detail.

Addressing or resolving human resource issues requires empathy, active listening, effective communication, and conflict resolution skills. It involves understanding the nuances of human behaviour, managing emotions, building relationships, and fostering a positive work culture. Furthermore, HR issues are often ongoing and require continuous effort to address and resolve. The issues faced by seafarer are well known and players in the industry are involved in various practices on a regular basis such as:

1. **Careful Selection and Recruitment:** Organizations understand that hiring the right seafarer is crucial for the smooth functioning of a ship. All companies have proper recruitment processes in place, including screening, competency examination, psychometric testing, interviewing, verifying qualifications, for selecting the qualified and competent sea farers.
2. **Training and Development:** Ship and crew management companies provides training and development opportunities to its seafarers and put them through various training programmes to make them competent and compliant with industry regulations. Many companies also have on-board training programmes.
3. **Retention and Motivation:** Retaining seafarers is critical for the efficient operation of a ship. HR management try to address factors like challenging living conditions, uncertainty related to joining and signing off, compensation-related issues, they also provide incentives, recognition, etc. to motivate and retain sea farers.
4. **Discipline and Conflict Resolution:** Conflicts or disciplinary issues among seafarers can arise on board ships due to various reasons, such as cultural differences, personality clashes, and work-related stress. Generally, companies have established policies and procedures for conflict resolution, disciplinary action, and grievance handling to maintain a harmonious work environment and resolve issues on board a ship.
5. **Diversity and Inclusion:** Ships sometimes have a diverse crew from different nationalities, cultures, and backgrounds. Companies through its policies ensure that diversity and inclusion are promoted on board, and discrimination or harassment based on race, gender, religion, or other protected characteristics are not tolerated. Some companies also organize training and workshops related to diversity awareness, inclusion, and equal and fair opportunity for all.

6. **Compliance with Regulations:** Ships are subject to various regulations related to labor laws, safety, and security, including the International Labor Organization's Maritime Labor Convention (MLC) and International Maritime Organization (IMO) conventions. Companies ensure that the ship and its officers and crew are compliant with these regulations, including issues such as employment contracts, wages, working hours, and crew certification requirements.
7. **Emergency Response and Crisis Management:** Ships can face emergencies such as accidents, piracy, or natural disasters that require effective crisis management and emergency response. Companies have well established policies and procedures for emergency drills, communication protocols, and officers and crew training to ensure that all seafarers are prepared to handle such situations effectively.
8. **Pre-Joining Briefing:** The pre-joining briefing is a standard practice in the maritime industry aimed at ensuring that seafarers are adequately prepared for their contracts. Prior to boarding a vessel, the respective shipping company or manning agency conducts a comprehensive briefing to equip seafarers for their upcoming voyage. This briefing typically covers crucial areas such as:
 - i. **Vessel details:** The seafarer is briefed about the vessel's specifications, including its size, type, and cargo carrying capacity.
 - ii. **Voyage details:** The seafarer is informed about the planned route, the expected duration of the voyage, and the ports of call.
 - iii. **Safety and emergency procedures:** The seafarer is trained on the vessel's safety procedures, including evacuation drills, firefighting, and first aid.
 - iv. **Crew duties and responsibilities:** The seafarer is informed about their duties and responsibilities, including their role in the vessel's operations and their watchkeeping duties.
 - v. **Compliance requirements:** The seafarer is briefed on the compliance requirements of various regulatory bodies, including the International Maritime Organization (IMO), the International Labour Organization (ILO), and the Maritime Labour Convention (MLC).

9. Post-Sign Off Debriefing: When a seafarer completes their contract and signs off the vessel, they typically undergo a post-sign off debriefing.

This debriefing is conducted by the shipping company or the manning agency and aims to evaluate the seafarer's performance and gather feedback. The debriefing usually covers the following areas:

- i. Performance evaluation: The seafarer's performance during their contract is evaluated, including their technical skills, teamwork, and adherence to safety procedures.
- ii. Feedback gathering: The seafarer is given the opportunity to provide feedback on their experience, including any concerns or suggestions they may have.
- iii. Documentation and paperwork: The seafarer is briefed on the paperwork and documentation required for their sign off, including their contract, discharge book, and other relevant documents.
- iv. Future opportunities: The seafarer is informed about future job opportunities and provided with guidance on how to secure their next contract.

Overall, pre-joining briefing and post-sign off debriefing are essential components of a seafarer's journey in the merchant navy. They help to ensure that seafarers are well-prepared for their contracts and that their performance is evaluated and documented for future opportunities.

Above explanation demonstrates that industry recognizes the importance of effective human resource management on board ships for maintaining competent, motivated, and healthy seafarers, ensuring compliance with regulations, and promoting a safe and harmonious work environment.

However, despite having these measures in place, the industry still faces challenges with the mental and emotional wellbeing of seafarers.

The existing international regulations and policies are not enough to address this problem. There is a clear need for more vigilance and proactivity in managing and mitigating issues related to the overall wellbeing of seafarers.

6. ANCHORING WELLNESS, ADDRESSING MENTAL AND EMOTIONAL HEALTH CHALLENGES AMONG SAILORS:

The health and happiness of seafaring personnel are vital for the safe sailing and the protection of life and cargo at sea. It is time to give priority to the overall wellbeing of sailors on board and create a culture that supports their wellness. We will examine the significance of wellness as an anchor and discuss strategies to cope with mental and emotional health challenges that affect seafarers. We will also explore ways to foster a supportive work environment, promote self-care, and build resilience among sailors at sea.

Shipboard Leadership: Shipboard leadership is a crucial factor for the wellbeing and performance of seafarers. As discussed earlier, seafaring is a challenging and stressful profession that exposes seafarers to various physical and psychological hazards. Seafarers need strong and sensitive leaders on board who can provide them with guidance, support, feedback, recognition, and empowerment. Good leader is one who can keep his/her personal biases and preferences aside to create an environment for inclusion. Shipboard leaders can influence the mental health, resilience, job satisfaction, motivation, safety culture and teamwork of seafarers. Some of the key aspects of shipboard leadership that can help create a conducive environment for seafarers are:

1. **Coaching and mentoring:** Shipboard leaders should adopt a coaching style that helps seafarers develop their skills, confidence, and potential. Leaders should also provide mentoring and guidance to seafarers, especially to the cadets and junior officers.
2. **Communication and feedback:** Shipboard leaders should communicate and provide constructive feedback frequently to seafarers, The communication must be effective, clear, and respectful.
3. **Recognition and empowerment:** Shipboard leaders should from time to time recognize and appreciate the efforts and achievements of seafarers, both individually and as a team.
4. **Delegation:** Shipboard leaders should also empower seafarers by delegating tasks, giving them autonomy and involving them in decision-making.
5. **Support and care:** Shipboard leaders should show empathy and compassion to seafarers, especially during difficult times such as emergencies, accidents, or personal issues.

6. Diversity and inclusion: Shipboard leaders should respect and value the diversity of seafarers in terms of their nationality, culture, religion, gender, age, and personality. Leaders should also foster an inclusive culture on board that promotes mutual understanding, cooperation, and respect among seafarers.

Pre-Joining Briefing and Post Sign Off De-Briefing in presence of a counsellor: The mental and emotional well-being of seafarers is paramount in the maritime industry, and it is vital that their needs are addressed during routine practices of pre-joining briefing and post-sign off debriefing. In this regard, the presence of an independent counsellor would be important to ensure that seafarers receive adequate mental and emotional support.

The counsellor's role in pre-joining briefing will provide seafarers the essential coping mechanisms, help them understand the emotional impact of the job, and equip them with techniques to maintain their mental and emotional well-being while on board. This can go a long way in mitigating the unique challenges faced by seafarers such as isolation, long working hours, and homesickness.

Similarly, during post-sign off debriefing, the counsellor can help seafarers process their experiences, manage negative emotions, and provide support for their transition back to shore life. Seafarers often face challenges readjusting to life on land, and the counsellor's presence can facilitate this transition and help them cope with any challenges that may arise.

Preparing for the challenges of life on board: young seafarers should be aware of the unique challenges that they may encounter while living and working on a ship. These challenges may include long periods of separation from home, limited social interaction, and different cultures and working conditions. By understanding these challenges, youngsters can mentally prepare themselves and develop coping mechanisms.

Developing effective communication and interpersonal skills: Effective communication and interpersonal skills are crucial for success in any career, including the Merchant Navy. All seafarers need to learn how to communicate effectively with their fellow crew members, superiors, and other stakeholders on board. This includes understanding the importance of teamwork, conflict resolution, and building positive relationships with colleagues from diverse backgrounds.

Managing stress and fatigue: Working on a ship can be physically and mentally demanding, with long working hours, and unpredictable workloads. seafarers need to learn how to manage stress

and fatigue effectively to maintain their physical and mental well-being. This can include techniques such as time management, relaxation exercises, and getting adequate rest.

Coping with homesickness and isolation: Being away from family, friends, and familiar surroundings for extended periods can result in homesickness and isolation. Seafarers need to learn how to cope with these emotions and develop strategies to maintain their mental and emotional well-being. This can include staying connected with loved ones through regular communication, engaging in hobbies or activities that provide comfort, and seeking support from fellow crew members or professionals on board.

Developing resilience and adaptability: Life at sea can be unpredictable, with challenges and emergencies that may require quick thinking and decision-making. Seafarers need to develop resilience and adaptability to cope with unforeseen situations. This can include problem-solving skills, decision-making abilities, and the ability to stay calm and composed in challenging situations.

Internet and Connectivity: Shipowners, management and manning companies and maritime authorities should prioritize the well-being of sailors at sea by implementing policies and practices that promote healthy internet and connectivity use, provide opportunities for rest and relaxation, and facilitate meaningful social connections. By recognizing and addressing the dark side of connectivity, we can support the mental and emotional well-being of sailors, ensuring a healthier work environment onboard merchant ship.

Role of Counsellor; Sessions with a counsellor can play a vital role in ensuring the mental and emotional well-being of seafarers. The sessions with an independent counsellor provide a safe space for seafarers to express their thoughts and feelings without the fear of judgment. Counsellors can assist seafarers in developing coping strategies, improving emotional resilience, and managing stress and anxiety (Williams, 2015). Moreover, these sessions can also promote positive qualities such as empathy, active listening, and cooperation among officers, leading to better teamwork and communication on board. These skills can help seafarers build positive relationships with their fellow crew members, superiors leading to better teamwork and conflict resolution (Lloyd et al., 2020). Moreover, counsellors can also provide support and share ways to manage stress and fatigue (Bhatia et al., 2019). This session can also address issues such as homesickness and isolation, (Lloyd et al., 2020).

Educate and Raise Awareness: Educating employees about mental health and emotional well-being can help reduce stigma and increase awareness. Companies must provide training, workshops, and seminars on topics related to mental health, stress management, emotional intelligence, and self-care. This can empower employees to recognize signs of mental health concerns in themselves and their colleagues and seek appropriate support.

Availability of Resources for Holistic Wellbeing: Companies can consider having an independent dedicated resources to support seafarers mental and emotional wellbeing. This can include providing access to confidential counselling services (CCS), employee assistance programs (EAPs), mental health hotlines. These resources can provide employees with professional support and guidance when dealing with mental health challenges and can help reduce barriers to seeking help. Although some institutions and organizations offer these services, they need to be more effective and responsive.

Facilitate the Culture of Self-Care and Wellness: Shipping companies need to create a culture of self-care and wellness by providing resources and opportunities for employees to take care of their physical, mental, and emotional health. This can include wellness programs, mindfulness activities, exercise facilities, and access to healthy food options. Encouraging self-care and wellness can help employees develop healthy habits that support their mental and emotional well-being.

Role of family for a stress-free seafarer: Family members of seafarers play a vital role in supporting their wellbeing and performance. They should understand the challenges and demands of the profession and provide them with time and space to focus on their work. They should also avoid sharing too much stressful information that might distract or worry them. They should create a positive and confident environment at home that reassures their family person on board a ship.

7. CONCLUSION:

While the Merchant Navy offers exciting career prospects, it also presents unique challenges that can have a significant impact on the mental and emotional well-being of seafarers. It is imperative to acknowledge the importance of mental and emotional preparation for seafarers, regardless of their age or experience, before they embark on a voyage. Adequate mental and emotional preparation, including counselling sessions, connectivity with counsellors while on board, support

groups, and understanding and empathy from family, can equip seafarers with the tools to manage the challenges they may encounter at sea.

Prioritizing the mental and emotional health of seafarers is essential for creating a more robust and resilient workforce in the maritime industry. By taking these necessary steps, seafarers will be better equipped to thrive in their roles and make meaningful contributions to the industry. A healthy and productive maritime industry is one that values the well-being of its workers and recognizes the unique challenges they face, both on board and in their personal lives. In conclusion, prioritizing the mental and emotional health of seafarers is not only beneficial for them, but it also contributes to a thriving and sustainable maritime industry.

REFERENCES

Bhatia, N., Lalwani, A., & D'Souza, A. (2019). Mental Health at Sea: Insights and Challenges. *Indian Journal of Psychiatry*, 61(Suppl 4), S711-S716.

Bhatia, N., Rajpurohit, P., & Nair, S. (2019). Psychosocial Factors in Seafaring: A Review of Literature. *Indian Journal of Occupational and Environmental Medicine*, 23(1), 1-6. DOI: 10.4103/ijoem.IJOEM_68_18

Lloyd, S., Greenberg, N., & Houghton, R. (2020). Occupational stressors and mental health in navy warship personnel: Testing the mediating role of psychological resources. *Military Psychology*, 32(3), 192-203.

Hansen, H. L., & Jensen, O. C. (2017). Mental health at sea: The influence of voyage duration on seafarers' psychological well-being. *Maritime Psychology*, 34, 1-14. DOI: 10.1037/mar0000069

International Maritime Health Association (IMHA). (2019). Guidelines for Mental Health and Well-being of Seafarers.

Kalantonis, P., & Bohlmann, T. (2016). The influence of perceived job demands and resources on seafarers' fatigue and psychological well-being. *Maritime Psychology*, 33, 1-11. DOI: 10.1037/mar0000055

Lee, J. W., & Cho, Y. H. (2017). Factors influencing seafarers' job satisfaction and turnover intentions: A perspective of needs fulfillment and job embeddedness. *Maritime Psychology*, 34, 46-59. DOI: 10.1037/mar0000076

Roberts, S. E., & Marlow, P. B. (2016). Trajectories and predictors of stress and depression in Australian seafarers. *International Archives of Occupational and Environmental Health*, 89(2), 303-314. DOI: 10.1007/s00420-015-1051-6

Williams, A. (2015). Mental health and well-being of seafarers: A review of the literature. *Journal of Maritime Research*, 12(2), 13-24. DOI: 10.1007/s13437-015-0080-7.

AUTHOR



Dr. Poonam Kapoor, Ph.D., is an expert in Economics, specializing in International Trade in Services and Maritime Transport Services. She is also a professional counsellor, specializing in helping seafarers and cadets. Dr. Kapoor is the co-founder of ISF Group and director of ISF Maritime Services Pvt. Ltd. Additionally, she is the co-founder and president of the Inner Search Foundation, a charitable organization promoting yoga and wellness. Dr. Kapoor is currently developing 'The Confluence', a center for yoga sciences and sustainability in Maharashtra.

BUILDING AN ELECTRIC VEHICLE FOR A MARITIME CAMPUS

Dr. S. Thangalakshmi¹, Bessetty Ayush², Saad Khan², Raj Jitendra Singh² & Akshay A Kumar²

Abstract

This technical paper provides a detailed overview of the ongoing electric vehicle project in Indian Maritime University, Chennai Campus. The paper describes the development of various components of the vehicle at successive stages. The major components in chassis, differential, battery technology, charger station, motor, steering system, braking circuit and solar panels are examined. It defines the present market situation of concept vessels which are both efficient and economically feasible. The paper also contains illustrations in the form of rendered AUTOCAD images and actual prototype photographs. The objective is the build an electric vehicle which shall be used in the big Semmencherry Campus and also ply between the Uthandi and Semmencherry Campuses.

Keywords: Electric vehicle; energy efficiency; optimal transport solutions

1. INTRODUCTION

An electrical vehicle is a vehicle that harnesses its propulsive power from Electric Motors instead of conventional Internal Combustion Engines or Steam Driven Turbines. The electric motors may either derive their power (electric current) from extravehicular sources (Tram using electric power lines) or derive their power from batteries fitted on the vehicle. These batteries may in turn be charged with external grid power or by a generator, solar panels or fuel cells installed on the vehicle itself.

The biggest advantage of using battery and motors instead of Internal Combustion Engines is the high efficiency of power conversion from electric to mechanical through the electric motor. Secondly, the need to reduce carbon footprint has encouraged governments to support and subsidize EVs rather than conventional IC Engine driven vehicles.

¹ Faculty - Electrical, Indian Maritime University, Chennai Campus, Chennai, India
Email: thangalakshmi prakash@yahoo.com

² Cadet, B.Tech. (Marine Engineering), Indian Maritime University, Chennai Campus, Chennai, India

For any manufacturer to survive the present automobile sector, it has to develop at least one model in the hybrid electric vehicle segment. The popular models of EV models in the market are given in Table 1. Countries such as France and Japan are going to close the production of petrol vehicles by 2030.

Table 1- Types of EVs

Types of EVs	Hybrid EVs	Battery EVs	Fuel Cell EVs	Solar Cell
Energy System	Battery Ultra-Capacitor ICE Generator Unit	Battery Ultra-Capacitor	Fuel Cell	Solar Cell
Propulsion	Electric motor drive Internal combustion engines	Electric motor drives	Electric motor drives	Electric motor drives
Major issues	Managing multiple energy sources	Battery and battery management	Fuel cell cost Fuel processor	Solar Cell cost

It is important to note that EVs have lower operating costs as compared to conventional vehicles. The price of electricity on a day-to-day basis doesn't fluctuate and is more stable as compared to gas or liquid fuel. Therefore, with the help of EVs, we can reduce carbon footprint and the consumption of non-renewable energy resources like diesel and petrol.

It is important to note that EVs have lower operating costs as compared to conventional vehicles. The price of electricity on a day-to-day basis doesn't fluctuate and is more stable as compared to gas or liquid fuel. Therefore, with the help of EVs, we can reduce carbon footprint and the consumption of non-renewable energy resources like diesel and petrol.

2. NEED OF AN ELECTRIC VEHICLE FOR IMU CHENNAI CAMPUS

The Semmencherry Campus (SC) houses the Martine Engineering training facilities and the Head Quarters of the University. The SC has almost 100 acres of are under development out of 300 acres. There is a hostel and staff housing facilities also. Transportation and commuting inside the

SC are currently done using fossil-fuel burning vehicles. There have been measures to use more greener options (bicycles) and erection of a solar power plant etc.

The location and the layout of the two premises of Chennai Campus are shown in Figure 1.

The distance between the Academic and Administrative Block from the Residential Block inside Semmencherry premises is around 1Km and the distance between the Semmencherry premise and the Uthandi premise is around 2.5Km. With an EV, the dependence on these fossil-fuel burning vehicles to commute and transport will reduce and hence the Carbon emissions also.

Figure 1 - Map Showing Semmencherry and Uthandi Premises of IMU Chennai Campus

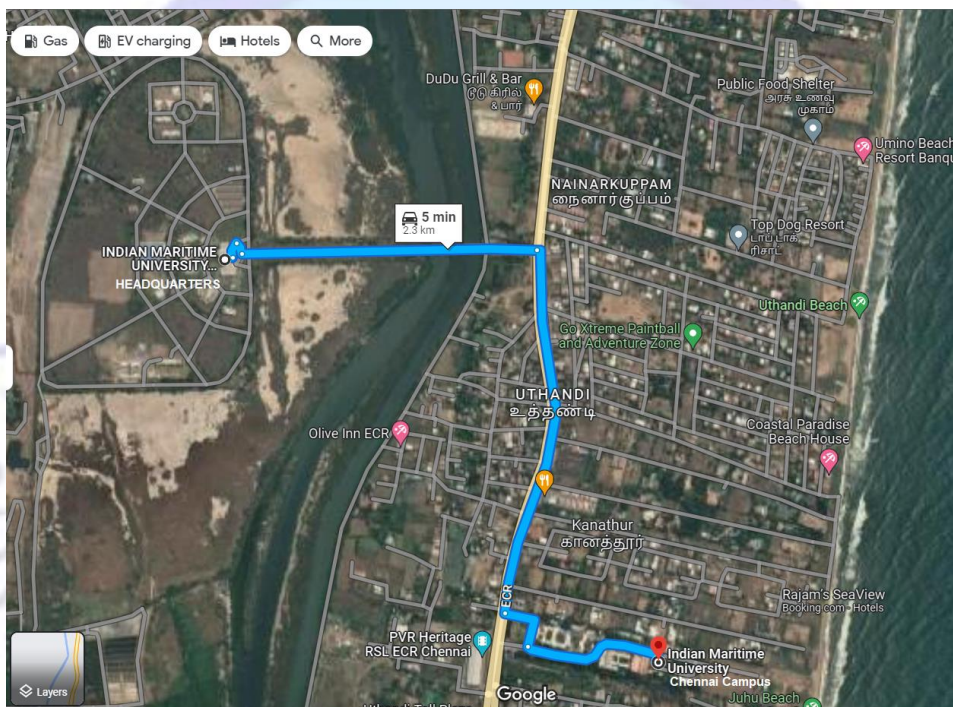

Hence, the idea of building an indigenous electric vehicle which will justify its purpose in serving the Green Campus of Indian Maritime University, Chennai is feasible. Using an EV for commuting will help both in the conservation of university resources and easy means of transport for faculty, staff and cadets.

The objectives of the project can be summarized as follows:

1. To evaluate the requirements of an Electric Vehicle suitable for Chennai Campus (Uthandi & Semmencherry premises).
2. To develop an effective and cost friendly Electric Vehicle.

3. To put the Vehicle into regular use on the Campus.
4. To identify future scope for operation and maintenance of the EV (e.g., charging station, maintenance bay etc.)

3. METHODOLOGY

The project is planned to be executed in five phases as depicted in Figure 2.

Figure 2- Flowchart describing the 5 phases of the project.

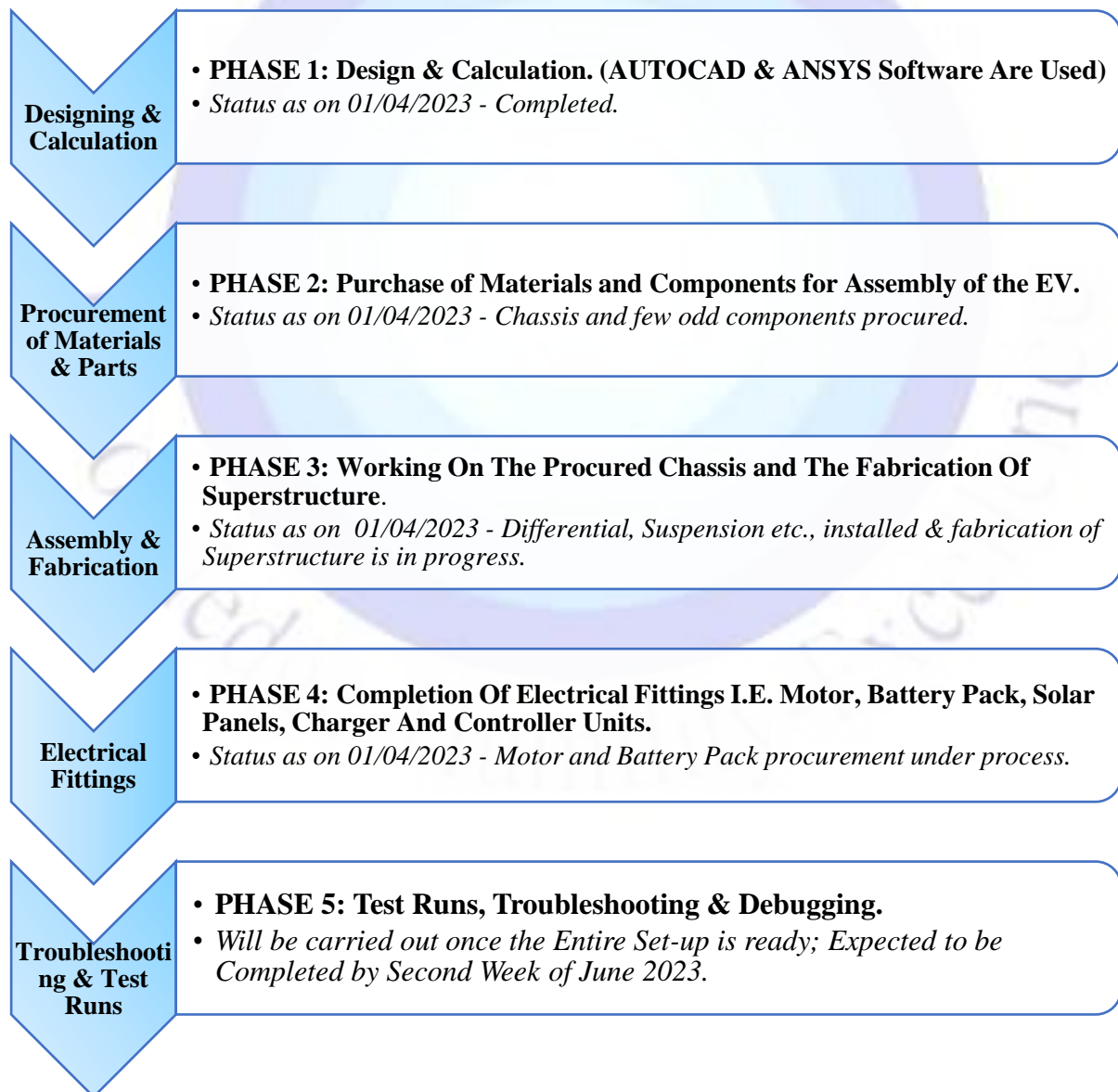

4. KEY COMPONENTS OF THE ELECTRIC VEHICLE

The electric vehicle has a simple lineup of components. Figure 3 depicts the Block Diagram arrangement, whereas Figure 4 illustrates an expanded diagram.

Figure 3 - Key Components in an EV

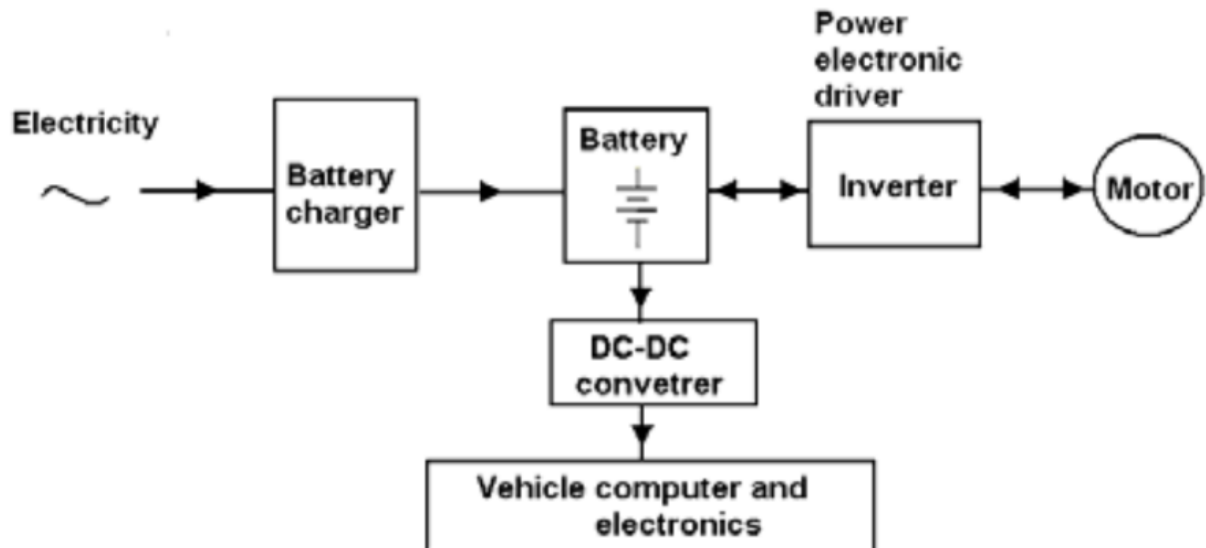

i. BLDC MOTOR

BLDC stands for brushless DC motors. They are the most used motors in electric vehicles because of their high starting torque, traction characteristics and high efficiency. BLDC works on both DC and AC input; commutator and brushes are not part of BLDC motors.

Motor receives the input as AC which is received via a controller, converter and inverter which inputs the required AC signal to the motor to produce the required power. Power from the motor is transferred through a rear differential to the rear wheels of the car. For our electric vehicle (EV) we are using 30 kw, 84v BLDC motor and reason for choosing it is given in the calculations.

The number of motors used in an EV depends on the type of drivetrain the vehicle is using. For example, All Wheel Drive (AWD) EVs use more than one motor. Whereas Rear Wheel Drive (RWD) or Front Wheel Drive (FWD) EVs use only one motor each connected to rear or front differential respectively. High Performance EVs such as the Tesla Model S use a total of four motors for four wheels.

The prototype being developed will have a single motor connected to the rear differential giving the vehicle a Rear-Wheel-Drive train.

ii. Battery pack for EV

Battery pack or also called traction battery pack is the component which supplies DC power to motor control unit which changes the DC supply to AC supply to the motor.

Battery packs are rechargeable li-ion batteries connected in series or parallel or both based on the voltage and current requirement of the motor.

Battery packs are recharged by an external source through a dc charger which is controlled by a dc charger controller.

In our electric vehicle we have also proposed to use solar panels to charge our Lithium Ferro Phosphate Battery Pack, 144V, Rated Current -31 A, Peak Current-250 A, with the support of an external charger.

iii. Motor controller

Motor controller, a PID controller consists of an inverter, converter and power electronics controller to control the motor output by changing its ac input. It receives signals from ignition switch, accelerator and forward-reverse switch to control the motor.

The inverter used is a bi-directional type which can be used in regenerative braking to charge the batteries in braking. The converter used is 12 V-60 V type.

iv. Auxiliary battery

These batteries are used for auxiliary equipment like head- tail lights, electronic indicators and other car accessories and in the case of failure of battery pack it can work to support the integral systems. The battery used in EV is a 6 V, 4.5Ah, li-ion battery and it is charged from the battery pack and the running condition.

v. DC charger controller

The battery pack is charges through DC supply from external source and solar panels, to control this dc supply to battery pack we use this controller.

vi. *Solar panels*

Solar panels are used as a charging module for the EV using renewable source of energy which is solar energy. We have planned to install mono-crystalline solar panels on the top of our electric vehicle. The photovoltaic cells convert solar irradiance into electric current which can be used to charge the electric vehicle.

vii. *DC charger*

Battery pack uses dc supply to charge the battery pack; DC charger is an external module which converts the grid AC supply into DC supply to charge the electric vehicle.

It works in parallel with solar panel when docked at a charging station to charge the battery pack.

Figure 4 - EV Block Diagram

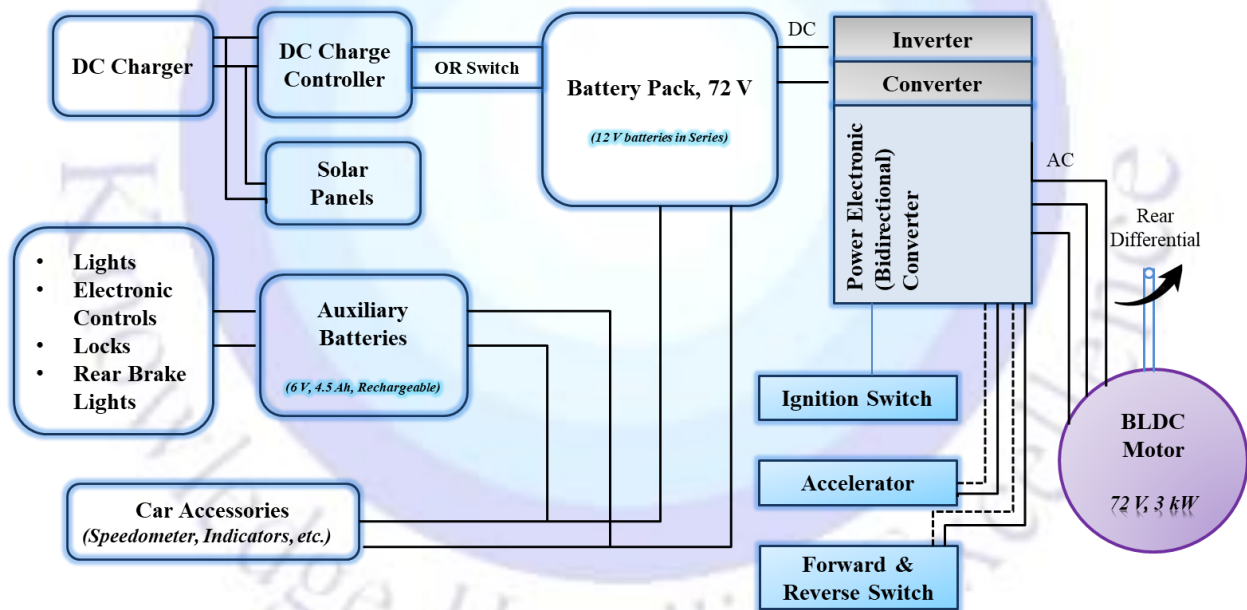

5. AUTOCAD DESIGN

The following figures illustrate the basic frame structure and after body work design with relevant dimensions of the EV prototype that were designed on AUTOCAD.

Figure 5 - Side View (Dimensions other than wheelbases are approximate values only)

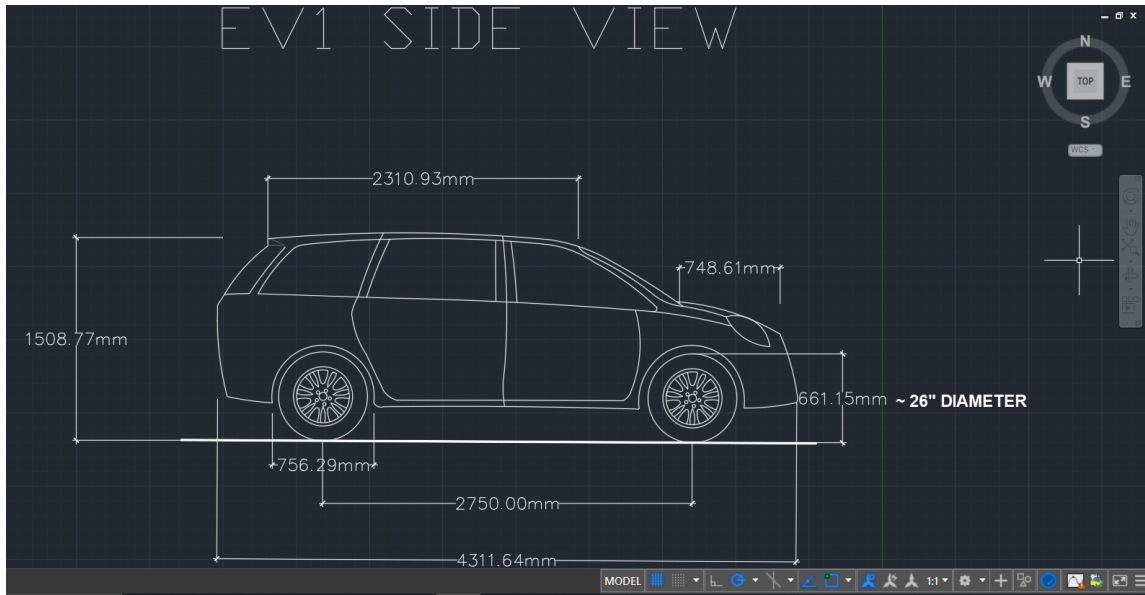
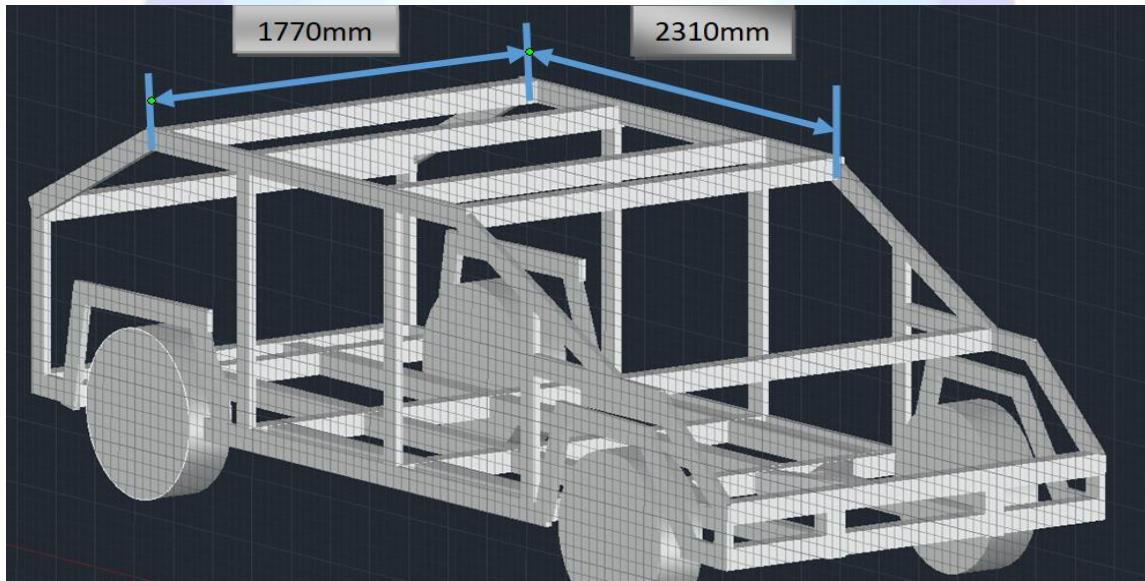

Figure 6 - 3D View of Frame Structure



6. ENERGY STORAGE

6.1 Batteries

Battery Pack is the energy storage in an EV. In recent times, a number of research studies are being pursued in the development of battery packs. Li-ion Battery is currently the most used battery in electric vehicles. The danger of the instability of the battery has been studied in many experiments.

The Lithium Ferro Phosphate (LiFePO₄) type Battery is preferable because of its chemically stable and inherent nature. Other Lithium-ion such as LiCoO₂, Li (Ni_{1/3}Mn_{1/3}Co_{1/3}) O₂ and LiMn₂O₄ have the thermal and overcharge concern. But Lead-acid batteries are still dominant in the market because of their relatively low cost.

Alternative for future prototypes - Ultra-capacitor

A capacitor is a static component having no chemical reaction in its components. Its charging and discharging speeds are very fast as compared to batteries. However, the energy storage is limited.

In particular the energy storage density is less than 20% of the lead-acid battery. The number of cycles and the temperature range is excellent. Table 2 shows the comparison.

Table 2 - Comparison of different energy storage unit

	Lead Acid	NiMH	Li-ion	Ultra-Capacitor
Energy Density (Whr/kg)	40	70	110	5
Cycle Life	500	800	1,000	500,000
Working Temperature(°C)	-30 ~ +50	-40 ~ +50	-40 ~ +60	-40 ~ +85
Cost \$/k Whr	1,000	2,400	5,000	50,000

Thus, ultra-capacitor is useful for fast speed or transient energy storage because it allows high current charging, its charging time can be shortened to within a few minutes. It is still in the initial stages of development. As per the general trend, it is expected that the costs will reduce, and the energy density will go up rapidly in the next few years.

7. CHARGING SYSTEM

7.1 General charger

The charger needed for the battery system for slow charging or fast charger are both required to handle high power. The H-bridge power converter is needed. Figure 4 shows the converter. The converter is famous for its efficiency and has found application in charger and DC-DC converter.

Figure 7 - The H-bridge converter for charger

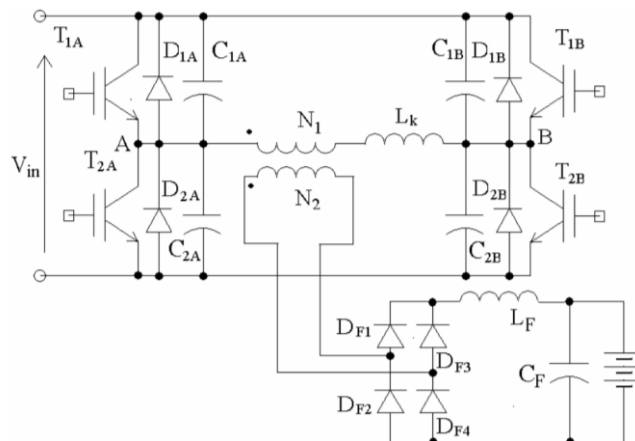

7.2 Alternative for future prototypes - Battery management systems

It is also referred to as BMS. The battery system is formed by a number of battery cells. They are connected in parallel or series that is according to the design. Each of the cells should be monitored and regulated. The conditioning monitoring includes the voltage, current and temperature.

Two parameters are usually provided. The SoH is to record the health or aging condition. There are a few definitions but the prominent one is:

$$SoH = \frac{\text{Nominal Capacity} - \text{Loss of Capacity}}{\text{Nominal Capacity}}$$

Figure 8 - Schematic Diagram of BMS

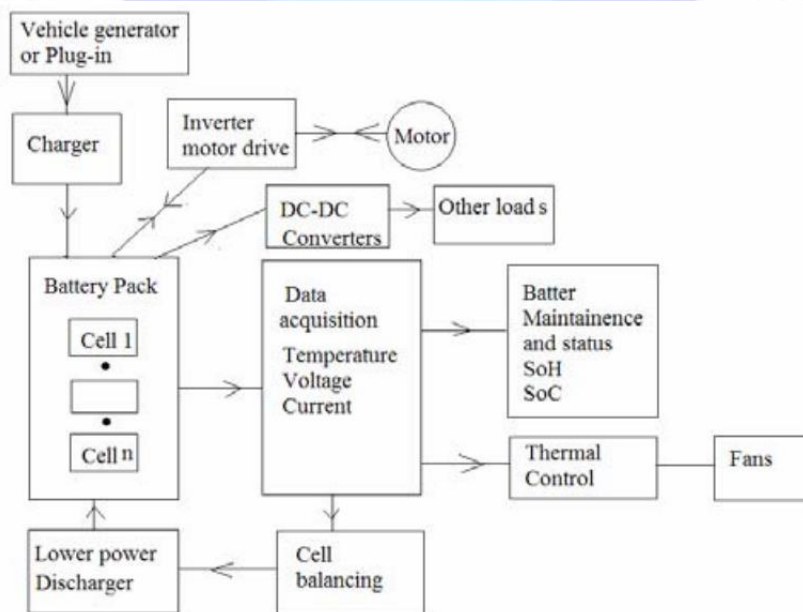

7.3 Charging Network

The charging method of EV is controversial because of the uncertainty of the power needed, location and the charging time. The charging time of batteries has been reported to be shorter in the recent development. The lead-acid batteries are restricted by their technology.

The charging rate is less than 0.2C and quicker charging rate seriously shortens its lifetime. Other batteries such as Li-ion has recommended charging rate of 0.5C.

Usually most of the electric vehicles have an on-board battery charger. A power cable is connected from the vehicle to a charging point. A charging station should provide a number of power points and a suitable transaction program to calculate the tariff.

The power needed for the charging station is not a concern. Usually for private car, a standard charging power is less than 2.8 kW. Single-phase power line is used. In average a vehicle is needed to be charged every 3 days. Using Hong Kong as an example, it will only affect the power consumption of less than 2% even all the private cars are charged to EV.

8. STRUCTURAL ANALYSIS OF INNOVA 2013 CHASSIS

The Chassis of an automobile is a skeletal frame on which most of the mechanical parts such as the engine, axle assembly, tires, brakes, differential etc. are fitted. The chassis is the most significant component of a vehicle.

It gives flexibility, stability and strength to the automobile under a wide range of real-life conditions. Automotive frames are mainly manufactured from Steel and Aluminum.

The front frame is a network of metal beams that forms the framework which also supports the front wheels. This provides the strength needed for the supporting components and payload placed upon it.

The chassis procured for the project is of Toyota Innova 2013 model.

Figure 97 - Rectangular Section & Stress Distribution in Chassis

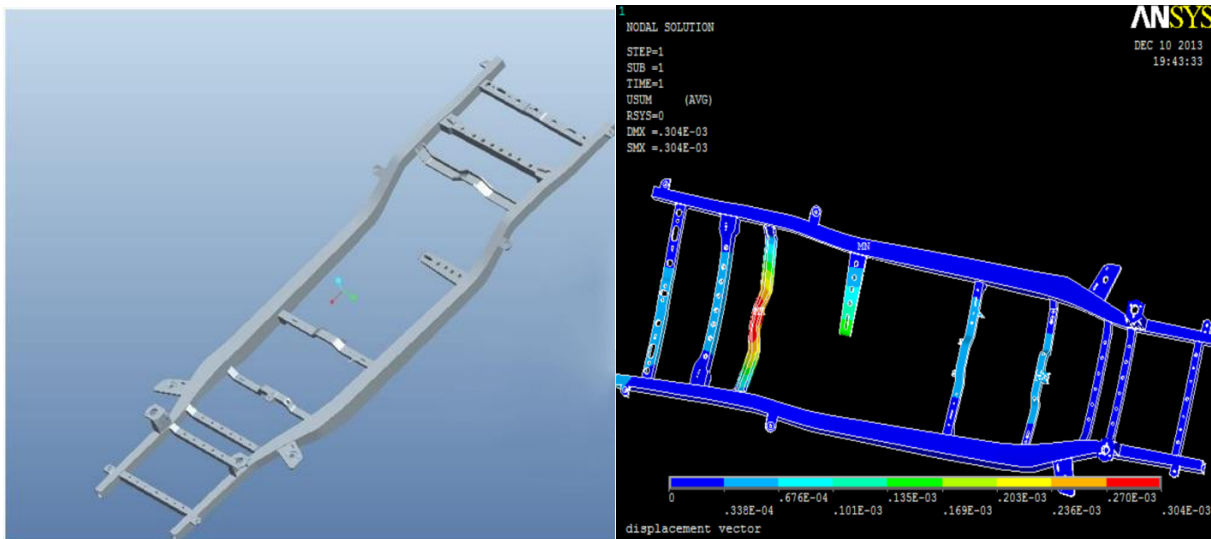

A 3D model of the Innova chassis is used for analysis in the ANSYS software. The loading conditions are considered to be constant. The element chosen in the software is the “SOLID-186” which is a higher order of the 3D 20 node solid element that exhibits quadratic displacement behavior.

The element is inherently defined by 20 individual nodes which have 3 degrees of freedom per node, that is translations in the nodal x, y & z directions. SOLID186 supports plasticity, large deflection, hyper elasticity, stress stiffening, creep and large strain capabilities.

8.1 Basic Calculation for Rectangular Cross Section

Gross Vehicle weight = 1200 kg

The gross vehicle weight is applied in the form of pressure.

The total area of application of load as calculated from chassis dimensions = 1525175 mm².

Hence the total load to be applied = $1200 \times 9.81 = 11772.0$ N

Pressure to be applied = $11772.0 / 1525175 = 0.00771845854$ MPa

8.2 Result Summary

Table 3 - ANSYS Result Summary

TYPE	STRESS INTENSITY (Mpa)	VON MISES STRESS (Mpa)	TOTAL DEFORMATION (mm)
Rectangular cross Section(original)	69.954	63.857	0.00026

Figure 10 - Photographs of Chassis before and after installation of parts



9. BRAKING

Disc Brakes and Drum Brakes have been the most common types of braking systems available in the market. An Electric Vehicle should incorporate both mechanical and electrical braking. In this type of hybrid braking, initially electrical power is regenerated with the concept of electrical braking where during deceleration, the kinetic energy of the vehicle is returned to the battery pack.

After this process is completed, mechanical braking is used in the final region of braking. This provides safety and energy saving.

Motors with relatively high power of regeneration are easily available in present day markets. To enhance the ability of power regeneration, the motor should have the ability to provide high reverse torque to stop the vehicle. This can be done using High Power Design Plugging Mode. The motor drive should be designed to incorporate a high frequency decoupling capacitor so as to absorb the fast transient of the reverse current.

10. SOLAR PANEL CALCULATIONS

Load = 10,000 W (RATED POWER) where PEAK POWER = 30,000 W

a. Inverter / UPS Rating:

Inverter / UPS rating should be greater than 25% of the total load (for the future load as well as taking losses in consideration)

$$10000 \times (25/100) = 2500\text{W}$$

$$\text{Our Load} + 25\% \text{ Extra Power} = 10000 + 2500 = \mathbf{12500 \text{ Watts}}$$

This is the rating of the UPS (Inverter) i.e., we need 12,500W UPS / Inverter for solar panel installation according to our need (based on calculations)

b. Required No & Backup Hours of Batteries

Suppose we are going to install **SIX 150Ah, 48 V batteries,**

$$48\text{V} \times 150\text{Ah} = \mathbf{7,200 \text{ Wh}}$$

Now for 6 Batteries

$$7200 \text{ Wh} \times 6 \text{ Batteries} = \mathbf{43,200 \text{ Wh}}$$

Now for one Battery (i.e., the Backup time of one battery)

$$7200 \text{ Wh} / 10,000 \text{ W} = \mathbf{0.72 \text{ Hours}}$$

Backup hours of 6 batteries:

$$= 43,200 \text{ Wh} / 10,000 \text{ W} = \mathbf{4.32 \text{ hours.}}$$

We will use 144V inverter system; therefore, we will have to connect **3 batteries in Series and the 2 sets of series in Parallel.**

Figure 11 - Battery Pack Arrangement

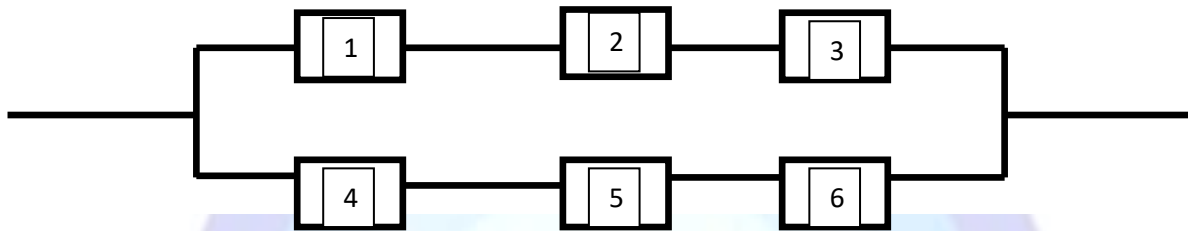

c. Charging Current for Batteries

Now the **Required Charging Current** for these two batteries.

(Charging current should be 1/10 of batteries Ah)

$$300\text{Ah} \times (1/10) = \mathbf{30\text{A}}$$

d. Charging Time required for Battery.

Here is the formula for the Charging Time of a Lead acid battery.

Charging Time of battery = Battery Ah / Charging Current

i.e., $\mathbf{T = Ah / A}$

For example, for a single 48V, 150Ah battery, the charging time would be:

$$T = \text{Ah} / \text{A} = 150\text{Ah} / 15\text{A} = 10 \text{ Hrs. (Ideal Case)}$$

Due to some losses, (it has been noted that 40% of losses occurred during the battery charging), this way, we take 15-18 A charging current instead of 15 A, this way, the charging time required for a 48V, 150Ah battery would be:

Charging Time = Battery Rating / Charging Current

Charging Time = (150Ah + (150Ah x (40/100))

Battery rating would be = 150Ah + 60 Ah = **210 Ah** (150Ah + losses)

Charging Time is = 210Ah / 18A = 11.67 Hours (ONLY BY SOLAR PANELS)

e. Required No of Solar Panels (Series or Parallel)

DC Load is Not Connected i.e. Only Battery Charging

$P = VI$ (Power = Voltage x Current)

Putting the values of batteries and charging current.

$P = 48V \times 15 A$

P = 720 Watts

This is the required wattage of solar panel (only for battery charging, and then battery will supply power to the load i.e., direct load is not connected to the solar panels)

720W/330W = 3 Nos of Solar panels

Therefore, a total of **3 Solar panels (each of 330W, 24V)** in series will be connected.

11. CONCLUSION

The Electric vehicle project is scheduled to be completed by June 2023. Future works including the development and installation of charging stations at strategic locations inside the Semmencherry and Uthandi premises are being worked upon simultaneously. The charging booths will utilize solar power in addition to being connected with the grid. Depending upon the success of this project, additional EVs will be developed in succession. The future prototypes will benefit from this project and will turn out to be more technologically advanced and efficient.

In the broader spectrum, electric vehicles hold a great promise to replace internal combustion engine vehicles (ICEVs) for a vast array of applications. They can address the carbon footprint by

reducing the reliance on fossil fuels, thereby improving air quality index by eliminating greenhouse gas emissions. Electrification of automobiles is imminent and is synchronous with the decarbonization trend of the twenty first century. Technology and governmental regulations can change societal mindset which will support the necessary transition toward a greener, efficient, and more affordable mobility solution for all.

ACKNOWLEDGEMENTS

The EV Project has been funded by the IMU Chennai Campus and we are thankful to the Campus Director, Dr. Rajoo Balaji for the funding and his continuous support. We wish to acknowledge the help extended by the Faculty of School of Marine Engineering Technology, IMU Chennai Campus.

REFERENCES

- Nagaraju, N. S., Kumar, M. V., & Koteswarao, U. (2013). Modeling and analysis of an innova car chassis frame by varying cross section. *International Journal of Engineering Research and Technology*, 2, 1-12.
- Muratori, M., Alexander, M., Arent, D., Bazilian, M., Cazzola, P., Dede, E. M., & Ward, J. (2021). The rise of electric vehicles—2020 status and future expectations. *Progress in Energy*, 3(2), 022002.
- Rahman, K. M., Fahimi, B., Suresh, G., Rajarathnam, A. V., & Ehsani, M. (2000). Advantages of switched reluctance motor applications to EV and HEV: design and control issues. *IEEE transactions on industry applications*, 36(1), 111-121.
- Williams, A. MIT Battery Breakthrough Could Revolutionize Electric Cars. March 12th, 2009 in *Batteries, Electric Cars (EVs)*.
- Jones, W. D. (2007). Putting electricity where the rubber meets the road [NEWS]. *IEEE Spectrum*, 44(7), 18-20.
- Schuss, C., Fabritius, T., Eichberger, B., & Rahkonen, T. (2019). Impacts on the output power of photovoltaics on top of electric and hybrid electric vehicles. *IEEE Transactions on Instrumentation and Measurement*, 69(5), 2449-2458.
- Yang, S., & Knickle, H. (2002). Design and analysis of aluminum/air battery system for electric vehicles. *Journal of power sources*, 112(1), 162-173.

Sufyan, M., Rahim, N. A., Muhammad, M. A., Tan, C. K., Raihan, S. R. S., & Bakar, A. H. A. (2020). Charge coordination and battery lifecycle analysis of electric vehicles with V2G implementation. *Electric Power Systems Research*, 184, 106307.

Peled, E., Golodnitsky, D., Mazor, H., Goor, M., & Avshalomov, S. (2011). Parameter analysis of a practical lithium-and sodium-air electric vehicle battery. *Journal of Power Sources*, 196(16), 6835-6840.

Tian, Y., Zeng, G., Rutt, A., Shi, T., Kim, H., Wang, J., ... & Ceder, G. (2020). Promises and challenges of next-generation “beyond Li-ion” batteries for electric vehicles and grid decarbonization. *Chemical reviews*, 121(3), 1623-1669.

Gan, J., Chau, K. T., Chan, C. C., & Jiang, J. Z. (2000). A new surface-inset, permanent-magnet, brushless DC motor drive for electric vehicles. *IEEE Transactions on Magnetics*, 36(5), 3810-3818.

Yildirim, M., Polat, M., & Kürüm, H. (2014, September). A survey on comparison of electric motor types and drives used for electric vehicles. In *2014 16th International Power Electronics and Motion Control Conference and Exposition* (pp. 218-223). IEEE.

Huang, C., Lei, F., Han, X., & Zhang, Z. (2019). Determination of modeling parameters for a brushless DC motor that satisfies the power performance of an electric vehicle. *Measurement and Control*, 52(7-8), 765-774.

Khan, M. A., Ahmed, A., Husain, I., Sozer, Y., & Badawy, M. (2015). Performance analysis of bidirectional DC–DC converters for electric vehicles. *IEEE transactions on industry applications*, 51(4), 3442-3452.

Jiang, J., Bao, Y., & Wang, L. Y. (2014). Topology of a bidirectional converter for energy interaction between electric vehicles and the grid. *Energies*, 7(8), 4858-4894.

AUTHORS

Dr. S. Thangalakshmi is a highly accomplished electrical and electronics engineer with extensive expertise in power system deregulation, distributed generation, relay coordination, renewable energy sources, smart grid, HVDC, and FACTS. She holds a bachelor’s degree, a master’s degree, and a Ph.D. in Electrical and Electronics Engineering.

Other authors include B. Tech Marine Engineering Cadets of Indian Maritime University, Chennai Campus, India.

Hindustan Institute of Maritime Training

Premier Research Partners of the International Maritime Research Confluence (IMRC 2020-2030)

THE FIRST WORD IN MARITIME TRAINING... HIMT

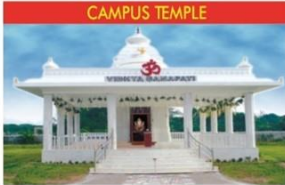

CAMPUS TEMPLE

Maintaining the record of being India's Largest Maritime Institute in terms of numbers of courses approved by DGS for over 15 years.

World's Largest Class DNV-GL awards 'Grade A1-OUTSTANDING' to all Postsea Competency courses & Presea courses.

HIMT has also been awarded DNV-GL Standard for Certification of "MARITIME TRAINING PROVIDER" in addition to having been awarded ISO 9001:2015 by Bureau Veritas (BV)

HIMT becomes the 1st institute in South India to commence various courses approved by Maritime & Coastguard Agency, United Kingdom (MCA, UK).

First Institute in South & East India to be Accredited by Nautical Institute, UK for Dynamic Positioning & Maintenance (DP) courses on Latest Kongsberg Simulator.

HIMT has received or been nominated for atleast one International I National Award every year for past 14 Years in the category Maritime Education & Training.

Winner of "Maritime Standard Award 2019" in the category of "The Maritime Education and Training" at Dubai on 21st Oct'19.

Mr. Sanjeev S Vakil, CEO, HIMT has been bestowed with National level VIBHUSHAN AWARD (Treasure of Shipping Award) for exemplary contribution to the Maritime Industry in the field of "Maritime Leadership" at Marex Kashti Awards 2019 at New Delhi on Oct'19.

Seafarers choice Awards for the Best Maritime Institute for Value Added Courses (South & East India) 2016 & 2018 by Offing etc.

Shipping Minister presents an Award for Excellence in Maritime Education & Training at the World Shipping Forum 2013.

Winner of Seatrade Award 2010, Dubai - Presented by former Secretary General of IMO.

Sanjeev S. Vakil, CEO, is World's first Marine Engineer to be conferred with the prestigious Fellowship by The Nautical Institute, UK.

The only Institute in India that has ranked by various rating agencies approved by the Director General of Shipping - SMERA, CRISIL, CARE, ICRA, LINV-GL and Class NK.

Entry Level to Advanced level training courses under one Umbrella with World Class Facilities.
One stop solution for all training needs...

Presea Courses

B.Tech (Marine Engineering) B.Sc (Nautical Science)
Graduate Marine Engineering (GME) Electro Technical Officer (ETO)
Orientation for Catering (OCCP) GP Rating (Engine/Deck)

Modular & Refresher courses: EFA / MFA / MC, PFF / AFF, PSSR, PST / PSCR, STSDSD / SSO, PSF / APS, High Voltage, VICT (TOTA), Tanker Familiarisation & Advanced courses.

Competency courses for All Grades of Nautical & Engineering exams of MMD / DGS including ECDIS, SMS, RANSCO, ROC / ARPA, ERS, ERSM, DECGS, LCHS



ADMINISTRATION BLOCK



ACCOMMODATION BLOCK



ACADEMIC BLOCK



KONGSBERG DP SIMULATOR



SHIP IN CAMPUS



INDIA'S LARGEST FIRE FIGHTING MOCK UP

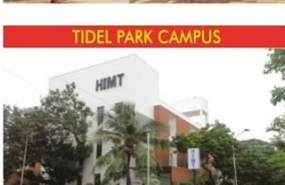

TIDEL PARK CAMPUS

APPROVED BY GOVT. OF INDIA BES AFFILIATED WITH IMU

GLOBAL MET MEMBER ISO 9001 : 2008 TRAINING PROVIDER

NAUTICAL AFFILIATE The Nautical Institute Seatrade Maritime Care & Indian Subcontinent Awards 2019 Winner

Maritime & Coastguard Agency
Training course recognised by the MCA

mca
Maritime and Coastguard Agency

HIMT

WHERE KNOWLEDGE IS WEALTH...

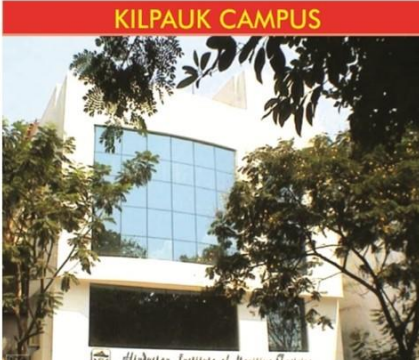

KILPAUK CAMPUS

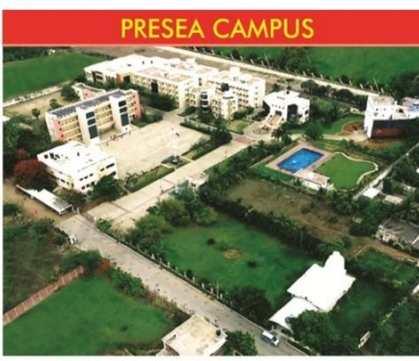

PRESEA CAMPUS



Hindustan Institute of Maritime Training

REGD. OFFICE: 11, Millers Road, Kilpauk, Chennai 600010, INDIA
TIDEL PARK CENTRE: 32, 4th Street, Dr. VSI Estate - Phase II, Near SRP Tools Signal, Thiruvannmiyur, Chennai, 600041, INDIA
PRE SEA CAMPUS: 55, East Coast Road, 72-B, Arambakkam, Vengampakkam Junction, Kalpakkam, Tamil Nadu 603102
Phone: 91 - 44 - 3010 3010 / 4343 9696 | www.himtmarine.com | www.himtcollege.com | E-mail: booking@himtmarine.com



ISF Institute of Research and Education (IIRE)

Developing and Delivering Integrated Educational and Research Programs

- ✓ **Benchmarking surveys**
- ✓ **Industry research**
- ✓ **Peer reviewed journal**
- ✓ **Working paper series**
- ✓ **White papers**
- ✓ **Application notes**
- ✓ **Training material distribution**
- ✓ **Book publishing**

Compensation and Benefits Surveys

IIRE has been conducting a 'Compensation and Benefits Survey' since 2009 for the for the sailing officers in various ranks of all types of merchant vessels of foreign shipping companies. The report of the survey has become necessary for the industry players helping them in positioning themselves with regards to wages of seafarers.



IIRE Journal of Maritime Research and Development (IJMRD)

IIRE Journal of Maritime Research and Development (IJMRD) is a platform for publication of articles, manuscripts, technical notes, etc. on a wide range of Maritime related topics. The academic works are reviewed by a panel of experienced academicians prior to publication.



ISF Working Paper Series (ISFIRE)

ISFIRE is a platform for authors in Economics to publish their research/book chapters, academic articles, reviews/notes which are under submission, or forthcoming elsewhere. The papers are reviewed by experts and eminent academicians.



Publishing of Books

IIRE is a one stop solution for publications with designing, proof reading and copy editing support. IIRE also has an ISBN number for its publications and supports distribution through online book stores.



ISF Group



Management & Consultancy

- Management of Institutes
- Design, Development and Delivery of Courses
- Quality Assurance
- Human Resource Management and Organizational Development

E - Solutions:

- E Learning and E Assessment,
- Competence, Aptitude, Psychometric Profiling
- Cadet Selection and Recruitment
- Learning Management Systems
- Audit and Inspections Reporting System
- Career Guidance Platform

We Serve ... We Care...

Training:

- Value Addition Programs for Officers & Ratings
- Electrical, Electronics, Automation
- Electronic Engines
- Soft Skills
- Safety Briefings
- Safety Officers Training
- Distance Learning Programmes

Research:

- Surveys;
 - Salary Surveys
 - Compensations and Benefits Exercises,
- Publication of Journals and Research Work



Inner Search Foundation



ISF Maritime Services Pvt. Ltd.



ISF Group International Pte. Ltd.
Singapore - www.isfgroup.com



ISF Institute of Research and Education (IIRE)
www.iire.in



NGO - Equality, Dignity and Safety



ISF Maritime and Offshore Institute



ISF Software and Publications
www.ispelearning.net



ISF Management and Consultancy Services



ISF Surveys, Testing, Audits Research & Rating Services



ISF HR Services



ISF Institute of Research and Education (IIRE)

A Division of Inner Search Foundation
410 Gemstar Commercial Complex, Ramchandra Lane Extension, Kachpada,
Off Link Road, Malad (W), Mumbai- 4000 64, India.
www.iire.in; www.inner-search.org; www.isfgroup.in